



**REACH, GMP & HAPI
CONTAINMENT**

***FLEXIBLE
ISOLATORS***

INDEX



DISPENSING



QC LABS & PILOT PLANTS



API & FINE CHEMICALS



FINISHED PRODUCTS



SPECIAL APPLICATIONS



TESTING



CONTAINMENT LEVEL MONITORING



SITE MOCK UP

SOLUTIONS TAILORED TO YOUR NEEDS

CSV CONTAINMENT DESIGN

- TAYLOR MADE
- CO DESIGNED WITH THE USER
- IMPROVED OPERATOR ERGONOMICS
- QUICK IMPLEMENTATION
- EASY TO MODIFY AND TO IMPROVE
- SUITABLE FOR HIGH CONTAINMENT
- SUITABLE FOR NEW OR EXISTING EQUIPMENT

CSV CONTAINMENT MATERIALS

- TRANSPARENT
- ANTISTATIC
- SOLVENT RESISTANT

CSV CONTAINMENT PROJECT

- REDUCED INVESTMENT COSTS
- FAST TRACK DELIVERY
- NOT INVASIVE INSTALLATION
- SMEPAC TESTED AND VALIDATED

CSV CONTAINMENT SERVICES

- FEASIBILITY STUDIES
- TRAINING
- FAT & MOCK-UP
- SMEPAC MONITORING
- VALIDATION

GMP MANUFACTURING IN CLEAN ROOM ENVIRONMENT

Our activity started with the CONTINUOUS LINER MANUFACTURING.

These Donuts are made of plastic material which is wound, compressed, and pre-packaged in order to obtain several meters of material which may be applied on discharge or transfer pipes, occupying the lowest amount of space. The **CONTINUOUS LINER**, packed in this way, allows to obtain cylindrical volumes (*drum liner*) which may be then unwound or unrolled from the Donut into the drum, making it possible to load dusty material avoiding any contact with the drum itself (*packaging*).

Most of all, the **CONTINUOUS LINER** makes it possible to **never open the discharge circuit**, replacing a drum with the following one during discharge/transfer phases, which usually require several containers.

An **extreme versatility** which allows the creation of several solutions in different shapes and colors, even specific ones, thus favouring the realization of **FLEXIBLE ISOLATORS** to confine all the **exposed** operations. Sometimes called **GLOVE BAGS** are similar to plastic bubbles equipped with gloves, filters, usually put into place as **AD HOC solutions for specific needs**, assessing which atmospheres must be sealed and molding the shapes which may be ergonomically more appropriate in order to allow for the best use by the operators.

The scope of our applications (*chemical-pharmaceutical*), has inevitably pushed us to increase the quality of our internal manufacturing capacity and quality, in terms of control and tracking of the production processes and supplied products as well as the environments in which the production, packaging and storage operations are carried out, in accordance to specific pharmaceutical requirements (*GMP or Good Manufacturing Practice*) and quality standard (*ISO 9001: 2015*).

This development has led to a radical transformation of the **MANUFACTURING FACILITY** towards an **ISO 7 and 8 classification**, using **areas with controlled atmosphere, filtered air, differential pressures cascade, clean room particle monitoring, separate material and personnel flows**.

In summary, environments, production processes, process controls and materials had to comply with the quality requirements indicated by pharmaceutical rules and practise as well as our customers requirements. Indeed, our customers have led the development of this process by suggesting the improvements needed to become a **Qualified flexible technology supplier**.

Our production process involves the use of basic material (low density polyethylene) directly supplied by CSV, rigorously certified and accompanied by the documentation required by the pharmaceutical industry. Furthermore, we can also **transform material provided by third parties or other suppliers** indicated by the final customers, **especially** in case **stability studies have already been carried out**. All of this, with the purpose to speeding up the production of the items required, without compromising the quality assessment on the **material already validated** by our customers.

The presence and use of qualified **automated heat-sealing equipment** allows a **RELIABLE and HIGH QUALITY MANUFACTURING** of **several designs of liners and flexible isolators**.

Given that our work can be considered as a form of **industrial tailoring**, we have **the habit of involving our final customers in the definition of the shape which they may like and need**, in order to ease the use of the devices, make their installation simple and their decontamination, removal or replacement quicker.



DISPENSING ISOLATOR (N₂ INJECTION)



- COMPACT AND MOVABLE
- PLUG AND PLAY UTILITIES
- TIGHT GAS ZIPPERED DOORS
- HUMIDITY CONTROL
- NITROGEN INJECTION

DISPENSING FLEXIBLE ISOLATOR



- COMPACT AND MOVABLE
- PLUG AND PLAY UTILITIES
- COLLAPSIBLE FRAME FOR STORAGE
- DESIGNED FOR ANY DISCHARGING INTERFACES/CONTAINERS
- OPTION WITH VENTILATION AVAILABLE
- NO SW AUTOMATION REQUIRED FOR PRESSURE CONTROL
- SUITABLE FOR HIGH CONTAINMENT

LIQUID DISPENSING & SAMPLING



- COMPACT AND MOVABLE
- NITROGEN INJECTION
- ZIPPERED DOORS
- PRODUCT CHARGE VIA CAMLOC/VALVE
- ISO 8 (GRADE D) INNER CHAMBER

DISPENSING AT CONTROLLED HUMIDITY



- COMPACT AND MOVABLE
- PLUG AND PLAY UTILITIES
- TIGHT GAS ZIP
- HUMIDITY CONTROL
- COMPRESSED AIR INJECTION

DOUBLE CHAMBER DISPENSING



- COMPACT AND MOVABLE
- BAG IN VIA FLEX PASS BOX
- ZIPPERED DOORS
- WASTE BAG OUT VIA CONTINUOUS LINER
- PRODUCT BAG OUT/DISCHARGING VIA SPLIT VALVE

VENTILATED DOUBLE CHAMBER DISPENSING

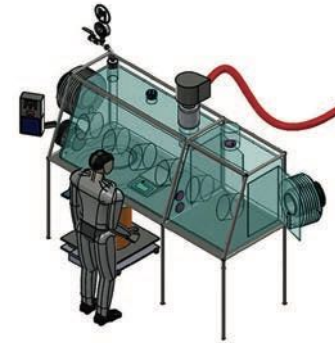

- NO CLEANING REQUIRED
- PLUG AND PLAY UTILITIES
- PASS BOX (PRE) AND MAIN CHAMBER VIA ZIPPERED DOORS
- INNER CHAMBER IN ISO 7
- SCALE POSITIONED OUTSIDE - NO PRODUCT CONTACT WITH THE SCALE
- API BAG IN VIA DRUM SLEEVE
- DISPENSED PRODUCT DISCHARGE BY CONTINUOUS LINER

DOUBLE CHAMBER ACTIVE N2 DISPENSING



- ZIPPERED DOUBLE CHAMBERS ISOLATOR
- WASTE BAG-OUT INTERFACE
- PRODUCT OFFLOAD/TRANSFER VIA EZIFLOW
- N2 ATMOSPHERE
- VENTURI NEGATIVE PRESSURE DEVICE
- QUICK SNAPS INSTALLATION

SPECIAL RTP BAG



- PU RTP BETA PORT MODIFIED TO BE INTERFACED TO A EZIFLOW CASSETTE
- CONTAINED LIQUID PRODUCT TRANSFER FROM ISOLATOR TO FINAL CONTAINER
- SPECIAL TRANSFER INTERFACE FOR DEVICES PASSING THROUGH A CLASSIC BETA PORT

BENCH FLEXIBLE ISOLATOR

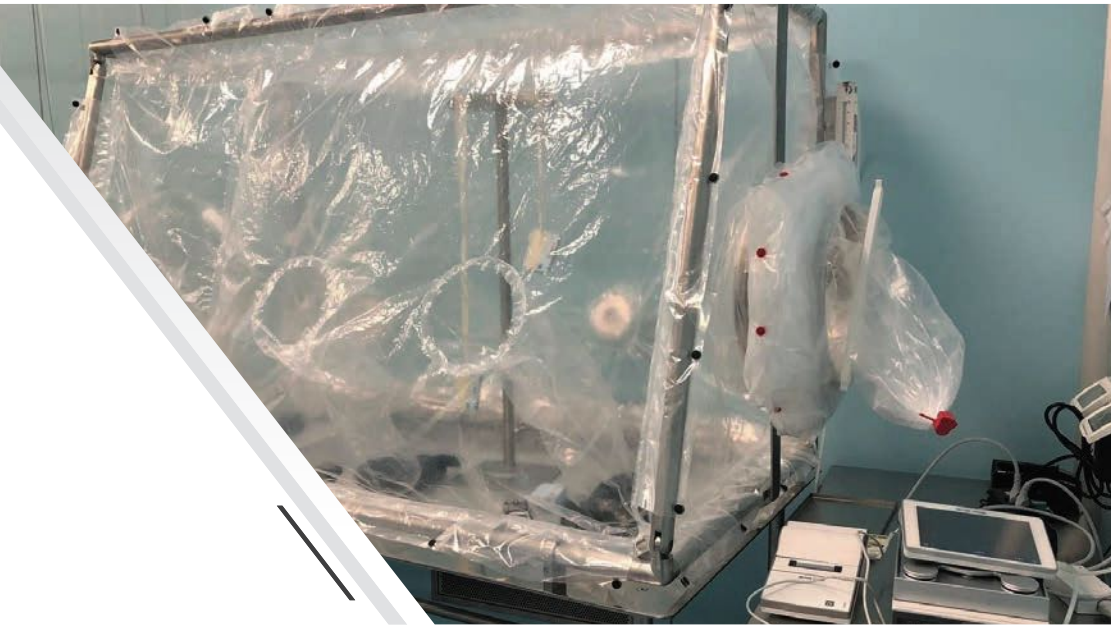
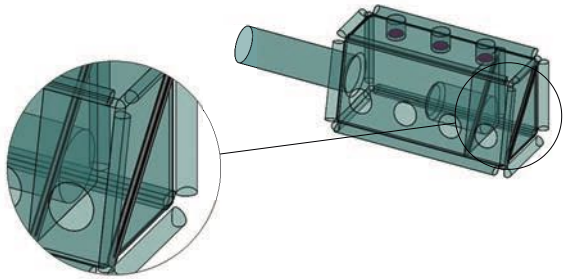

- ZIPPERED DOORS
- PRODUCT AND WASTE BAG OUT
- QUICK SNAPS INSTALLATION

QC LAB WEIGHT SCALE ISOLATOR

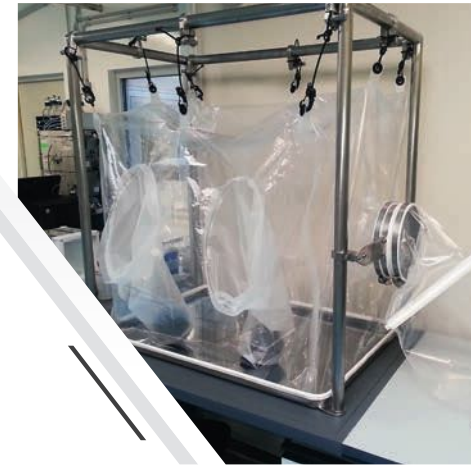
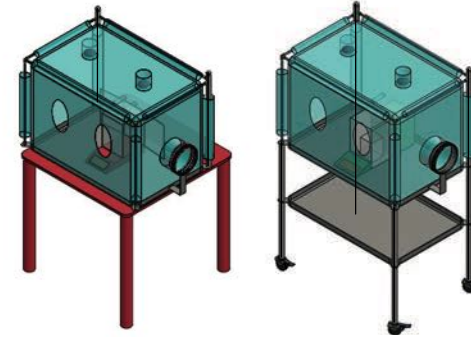

- COMPACT AND MOVABLE
- BAG IN BAG OUT VIA CONTINUOUS LINER

FLOW HOOD FLEXIBLE BARRIER

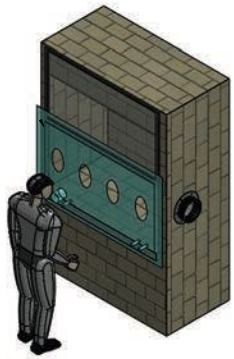

- COMPACT AND MOVABLE
- PLUG AND PLAY UTILITIES
- BAG IN BAG OUT VIA CONTINUOUS LINER

QC IR INSTRUMENT ISOLATOR

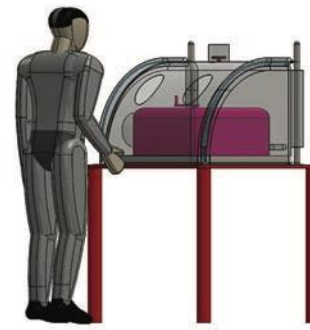

- COMPACT AND MOVABLE
- PLUG AND PLAY UTILITIES
- BAG IN BAG OUT VIA CONTINUOUS LINER

GMP GLASS REACTOR CHARGING



- GMP GLASS REACTOR DOUBLE BUTTERFLY INTERFACES
- FLUSHED BOTTLES
- INERT TRANSFER
- STEEL OR PLASTIC MADE VALVES

UNDER FLOW HOOD FLEX ISOLATOR

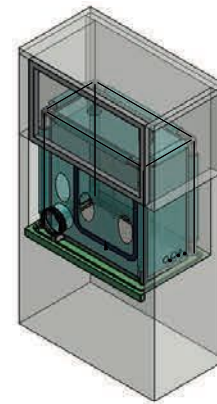

- COMPACT AND MOVABLE
- PLUG AND PLAY UTILITIES
- BAG IN BAG OUT VIA CONTINUOUS LINER
- GLASSWARE BAG IN /OUT VIA ZIPPERED INTERFACE

GLASS REACTOR CHARGING



- MAN-WAY CHARGING CONTAINMENT
- CONDUCTIVE MATERIALS (ATEX)
- PLUG AND PLAY INSTALLATION
- SOLVENT FREE OPERATIONS
- VACUUM AND PRESSURE TESTED VALVES (LIQUID AND GASES)

PILOT GLASS PLANT

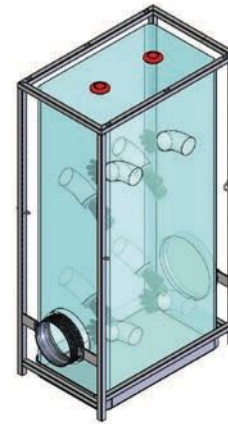

- FULLY CONTAINED CHARGING & SAMPLING
- N₂ INERTIZATION DECONTAMINATION
- CLEANING/DECONTAMINATION SPRAY GUN AVAILABLE

BUCKNER & TRAY DRIER CONTAINMENT

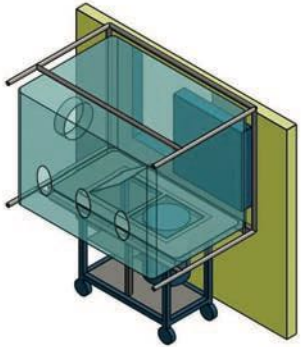

- COMBINATION BETWEEN
- RIGID ISOLATOR ON THE BUCKNER SKID
- FLEXIBLE ISOLATOR AROUND THE TRAY DRIER

BAG CHARGING STATION

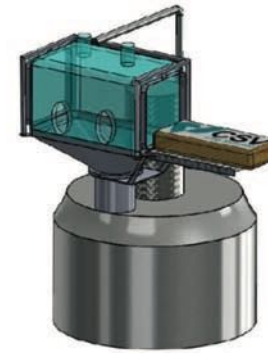

- BAG SWINGING CONVEYOR
- BAG FLAP DOOR

BENCH ISOLATOR



- COMPACT AND MOVABLE
- PLUG AND PLAY UTILITIES
- DESIGNED FOR ANY INTERFACES/CONTAINERS
- OPTION WITH VENTILATION AVAILABLE
- NO SW AUTOMATION REQUIRED FOR PRESSURE CONTROL
- SUITABLE FOR HIGH CONTAINMENT

SMALL SCALE CHARGING



- POWDER RESIDUAL RECOVERY BY SOLVENT FLUSHING
- N₂ COMPRESSED AIR OR SOLVENT INJECTION
- FLUIDS QUICK CONNECTION
- SUITABLE FOR ANY INTERFACE (SPLIT VALVES...)
- SUITABLE FOR ASEPTIC CHARGING

REACTOR CHARGING (MANWAY ADAPTOR)

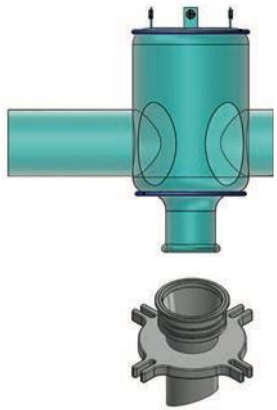

- PTFE MAN WAY ADAPTOR
- BAG OUT VIA CRIMPED SLEEVE
- BAG IN VIA ZIPPERED SLEEVE & WELOC

REACTOR CHARGING (DEDICATED FLANGE)

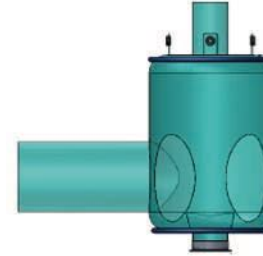

- 4" TC CONNECTION FLANGE
- BAG IN/OUT VIA ZIPPERED SLEEVE WITH WELOC PASS BOX

REACTOR CHARGING (ZIPPERED MANWAY NECK)

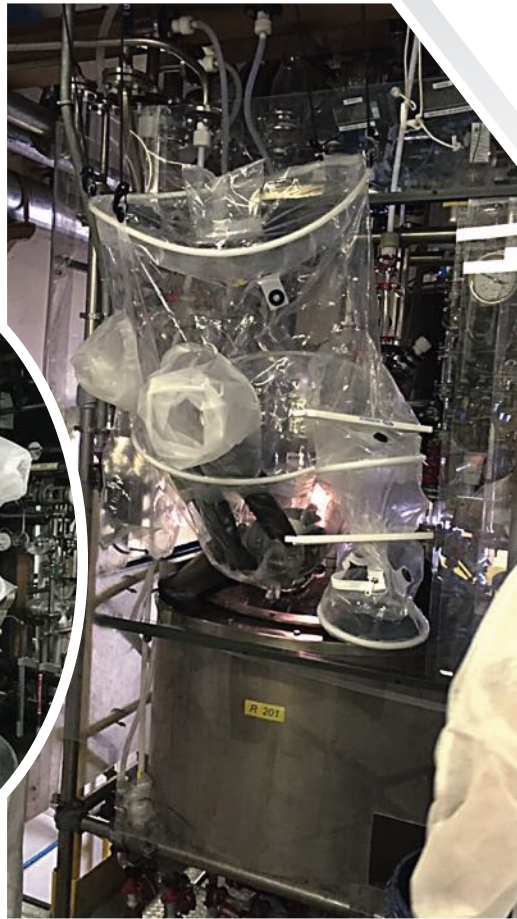
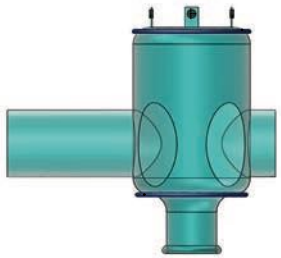

- BAG IN VIA ZIPPERED SLEEVE WITH WELOC PASS BOX
- INSTALLATION AROUND THE MAN-WAY NECK
- BAG OUT VIA CRIMPED SLEEVE

DOUBLE CHAMBER (ZIPPERED MANWAY NECK)

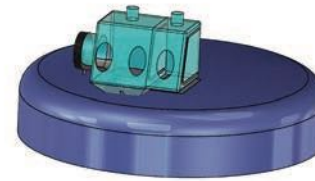

- PRE CHAMBER AND MAIN CHAMBER ZIPPERED DOORS
- BAG OUT CANISTER USED AS WORKING BENCH
- U GRIP OR ZIPPER TO SECURE THE BAG AROUND THE MANWAY OUTER NECK
- CLEAN CHARGING VIA INNER LINER NECK

PILOT BUCKNER FILTER

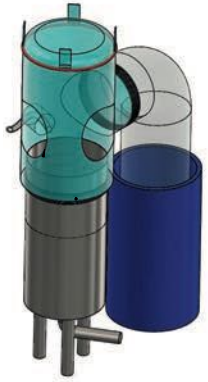

- COMPACT AND MOVABLE
- VALVE AND CAMLOC ON CHARGING LINE
- PRODUCT BAG OUT VIA LDPE SLEEVE

LENS FILTER



- COMPACT AND MOVABLE
- VALVE AND CAMLOC ON CHARGING LINE
- PRODUCT BAG OUT VIA LDPE SLEEVE

LIQUID CHARGING & SAMPLING



- COMPACT AND MOVABLE
- PLUG AND PLAY UTILITIES
- BAG IN VIA WELOC SLEEVE
- BAG OUT VIA CRIMPED SLEEVE

SPRAY DRYER ISOLATOR

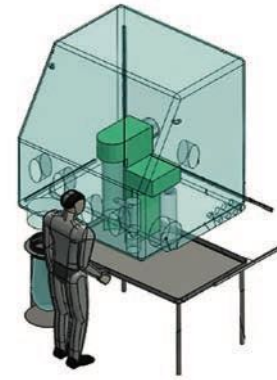

- COMPACT AND MOVABLE
- PLUG AND PLAY UTILITIES
- BAG IN BAG OUT VIA CONTINUOUS LINER

DOUBLE CHAMBER MILL CONTAINMENT

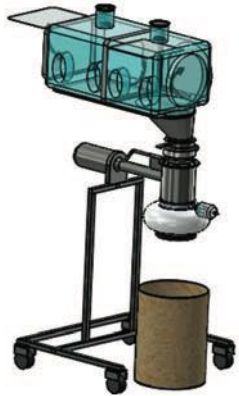

- CONTAINED LOADING AND OFFLOADING OPERATION
- SAMPLING & WEIGHING ON LINE OPTION AVAILABLE
- MAIN & PRE CHAMBERS (PASS BOX)
- N₂ INERTIZATION OF THE SYSTEM AVAILABLE
- IMPROVED OPERATOR ERGONOMICS

BAGS CHARGING STATION



- APPLICABLE TO:
 - MANWAY
 - DEDICATED FLANGE
- MOVABLE CONFIGURATION AVAILABLE
- TELESCOPIC CONFIGURATION AVAILABLE
- N₂ INJECTION AVAILABLE

MANWAY REACTOR CHARGING SLEEVE



- JUST SOFTGOODS
- NO UTILITIES REQUIRED
- N₂ INERTIZATION AVAILABLE
- NO GLOVES

SINGLE CHAMBER REACTOR CHARGING

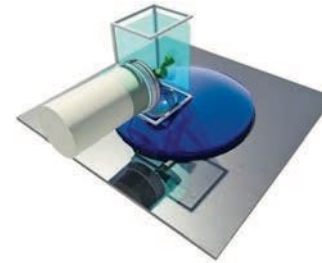

- APPLICABLE TO:
 - MANWAY
 - DEDICATED FLANGE
- DESIGNED FOR CONTAINED CHARGING OF:
 - DRUMS
 - BAGS
 - TINS
- MOVABLE CONFIGURATION AVAILABLE
- TELESCOPIC CONFIGURATION AVAILABLE
- NO UTILITIES REQUIRED
- N₂ INERTIZATION OF THE SYSTEM AVAILABLE

DOUBLE CHAMBER REACTOR CHARGING

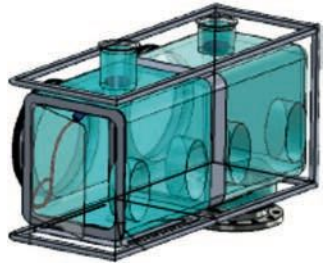

- APPLICABLE TO:
 - MANWAY
 - DEDICATED FLANGE
- DESIGNED FOR CONTAINED CHARGING OF:
 - DRUMS
 - BAGS
 - TINS
- MOVABLE CONFIGURATION AVAILABLE
- MAIN & PRE CHAMBERS (PASS BOX)
- NO UTILITIES REQUIRED
- N₂ INERTIZATION OF THE SYSTEM AVAILABLE

CONTINUOUS LINER & ON LINE SAMPLING



- CONTAINED OFFLOADING & SAMPLING INTO CONTINUOUS LINERS
- N₂ INERTIZATION AVAILABLE
- ON LINE WEIGHING & DOSING OPTIONS AVAILABLE
- DRUM LINER CONTAINED SEPARATION BY CRIMPING
- CIP & SIP OPTION AVAILABLE

HAPI REACTOR CHARGING FLEXIBLE ISOLATOR



- DOUBLE CHAMBER BAGS CHARGING ISOLATOR
- ZIPPERED DOORS
- WASTE BAG OUT
- QUICK SNAPS INSTALLATION
- MANWAY ADAPTOR CLAMP CONNECTED
- CLAMP ENDS TRANSFER SLEEVE

BAGS CHARGING II CHAMBERS FLEXIBLE ISOLATOR

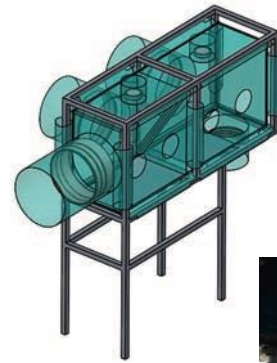

- DOUBLE CHAMBER BAGS CHARGING ISOLATOR
- ZIPPERED INTERNAL DOORS
- PRODUCT BAG IN AND WASTE BAG OUT VIA GROOVED CANISTERS
- QUICK SNAPS INSTALLATION
- NO STEEL SURFACE PRODUCT CONTACT
- N2 INJECTION
- PASSING TROUGH THE WALL QUICK CONNECTIONS

FILTER DRYER CAKE RECOVERY

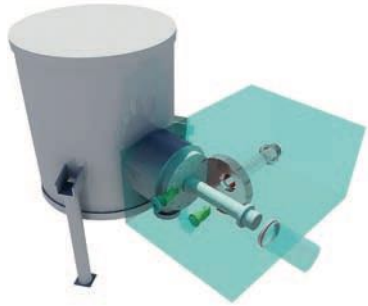

- CONTAINED AND SAFE BODY VALVE OPENING
- CONTAINED RESIDUAL PRODUCT RECOVERY
- CONTAINED GASKET & SEALS CLEANING
- PLUG AND PLAY INSTALLATION
- N₂ INERTIZATION OF THE SYSTEM AVAILABLE
- SOLVENT FREE OPERATIONS

MOBILE DISCHARGING CLEAN ROOM



- COMPACT AND MOVABLE
- FLEXIBLE CLEAN ROOM
- FAST RECOVERY TIME
- COMPRESSED AIR OR N₂ QUICK CONNECTION AVAILABLE
- HEPA FILTERS ON BOARD
- DESIGNED FOR ANY DISCHARGING INTERFACES/CONTAINERS
- EASY TO INSTALL AND REMOVE

CENTRIFUGE SCOOPING OUT

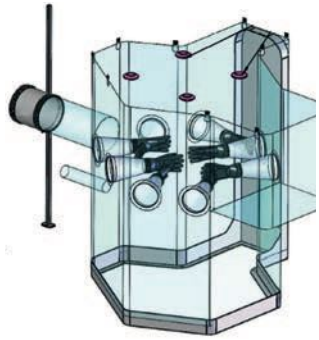

- FLEXIBLE CLEAN ROOM ENVIRONMENT
- FAST RECOVERY TIME
- COMPRESSED AIR OR N₂ QUICK CONNECTION AVAILABLE
- HEPA FILTERS ON BOARD

LID OPENING ENCLOSURE



- GMP & SAFE ENCLOSED EXPOSED OPERATION
- CONTAINED AND SAFE PRODUCT RECOVERY
- PLUG AND PLAY INSTALLATION
- N₂ INERTIZATION OF THE SYSTEM AVAILABLE
- SOLVENT FREE OPERATIONS
- INTERNAL GAS MONITORING

BASKET CENTRIFUGE OFFLOADING

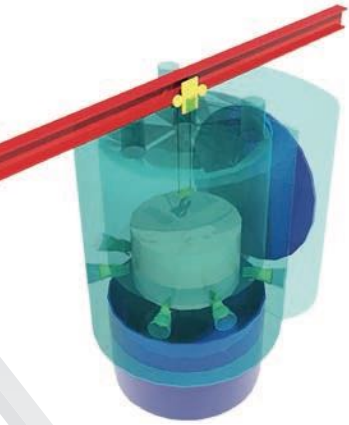

- GMP & SAFE CENTRIFUGE OFFLOADING
- FLEXIBLE CLEAN ROOM ENVIRONMENT
- FAST RECOVERY TIME
- COMPRESSED AIR OR N₂ QUICK CONNECTION AVAILABLE
- HEPA FILTERS ON BOARD
- EASY TO INSTALL

FILTER DRYER VALVE CLEANING

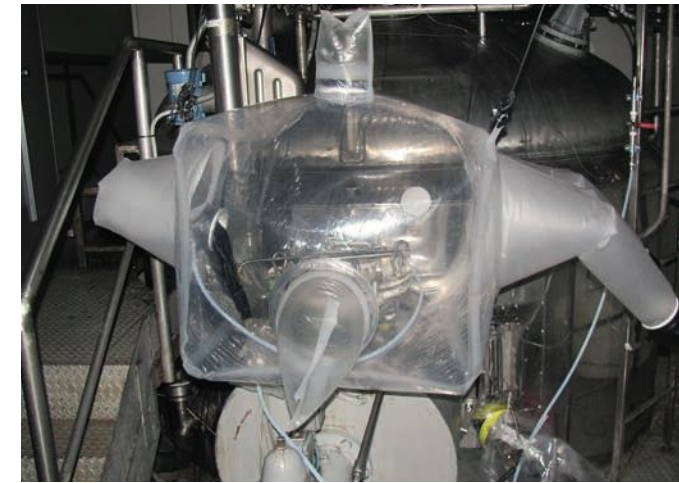
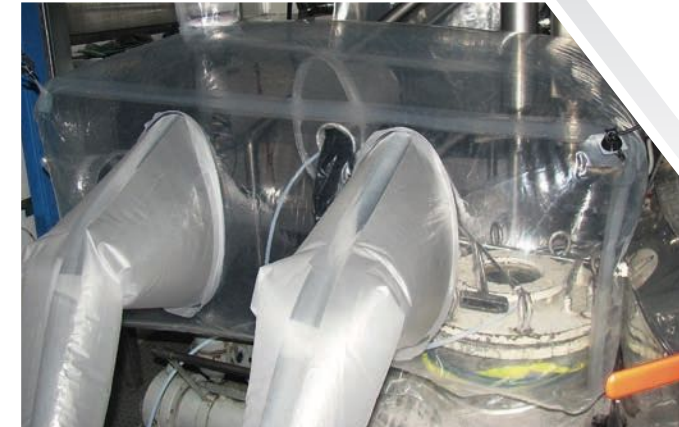
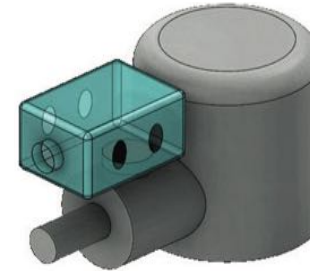

- EASY TO INSTALL AROUND THE INSPECTION FLANGE
- NO HARDWARE REQUIRED
- NITROGEN INJECTION AND VENT EXTRACTION

FILTER DRYER CAKE REMOVAL

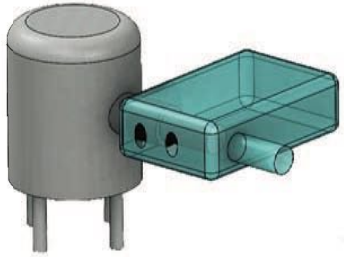

- EASY TO INSTALL AROUND THE DISCHARGE BODY
- NO HARDWARE REQUIRED
- NITROGEN INJECTION AND VENT EXTRACTION AVAILABLE

X-AXIS CENTRIFUGE CONTAINMENT

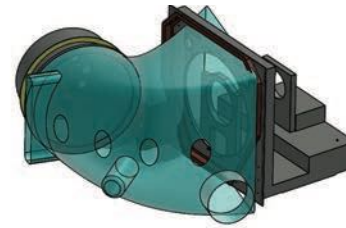

- NO HARDWARE REQUIRED
- NITROGEN INJECTION AND VENT EXTRACTION AVAILABLE
- BAG IN BAG OUT VIA INTERFACE CANISTER AND SLEEVE

DRUM CHARGING SINGLE CHAMBER FLEXIBLE ISOLATOR

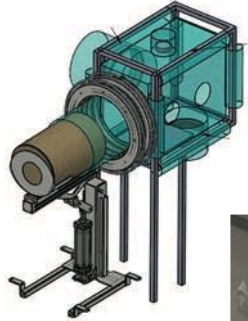

- SINGLE CHAMBER DRUM CHARGING ISOLATOR
- PRODUCT BAG IN AND WASTE BAG OUT VIA GROOVED CANISTERS
- QUICK SNAPS INSTALLATION
- NO STEEL SURFACE PRODUCT CONTACT

VACUUM TRANSFER CONTAINMENT



- GMP & CONTAINED DRUM TRANSFER BY VACUUM
- LIGHT & EASY TO USE
- COMPACT AND MOVABLE
- IMPROVED OPERATOR ERGONOMICS
- NO UTILITIES REQUIRED
- AVAILABLE OPTION WITH VENTILATION
- N₂ INERTIZATION OF THE SYSTEM AVAILABLE
- SUITABLE FOR DIFFERENT PNEUMATIC CONVEYORS

FLUID BED DRIER



- CONTAINED LOADING AND OFFLOADING OPERATION
- CONTAINED RESIDUAL PRODUCT RECOVERY
- SAFE & CONTAINED FILTERS CHANGE
- IMPROVED OPERATOR ERGONOMICS

WET GRANULATOR

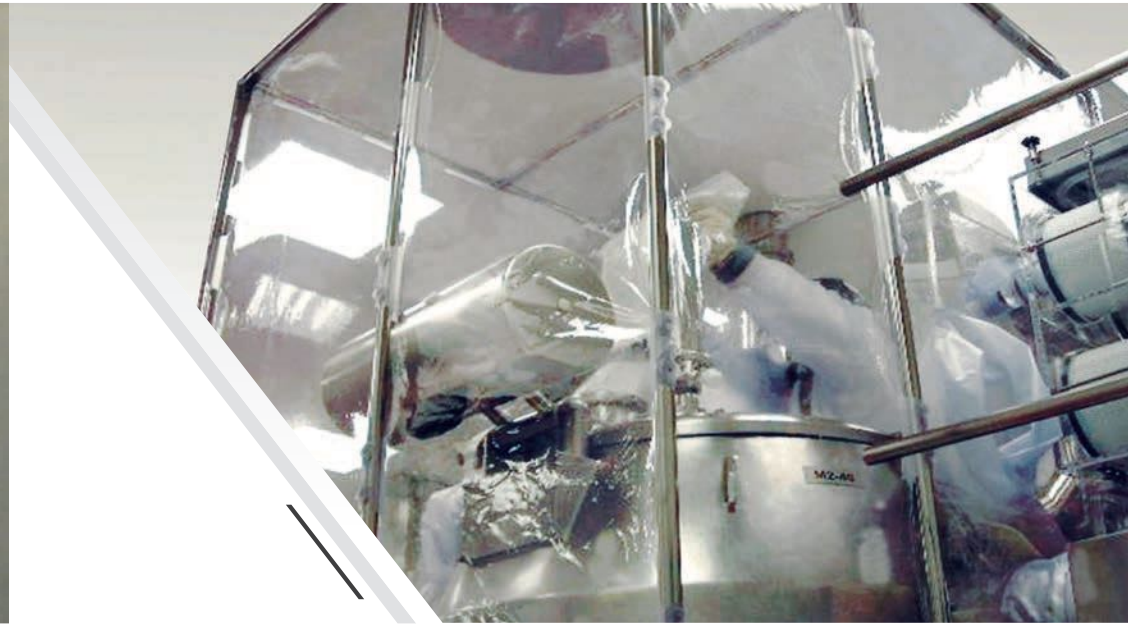

- SAFE OFFLOADING
- CONTAINED RESIDUAL PRODUCT RECOVERY
- CONTAINED GASKET & SEALS CLEANING
- PLUG AND PLAY INSTALLATION
- N₂ INERTIZATION OF THE SYSTEM AVAILABLE
- SOLVENT FREE OPERATIONS
- IMPROVED OPERATOR ERGONOMICS

MILL CONTAINMENT

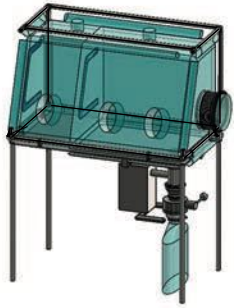

- DOUBLE CHAMBER WITH ZIPPERED PASS BOX
- ON LINE MILL LOADING
- ON LINE MILL OFFLOADING VIA SPLIT VALVE AND CHARGE BAG

SIEVER CHARGING/DISCHARGING

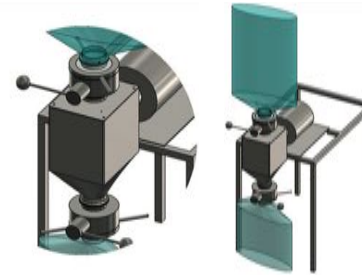

- ON LINE SIEVER CHARGING AND OFFLOADING VIA SPLIT VALVE AND CHARGE BAG

ROTATING DRYER CONTAINM



- BLENDER CHARGING, SAMPLING AND OFFLOADING VIA SPLIT VALVE AND CHARGE BAG

TABLETTING / CAPSULE FILLING CHARGING



- TABLET PRESS MACHINE CHARGING VIA SPLIT VALVE AND CHARGE BAG

TOXIC LIQUID TRANSFER CONTAINMENT



- COLLAPSABLE DRUM FLEXIBLE ISOLATOR
- LIFTING UP/DOWN DRUM AND LANCE CANISTERS ALLOWING EASY LANCE INSERTION AND CONTAINED SEPARATION
- STUB BAG OUT VIA CONTINUOUS LINER
- QUICK PROCESS CONNECTION FOR N2 INJECTION

ROTATING DRYER CONTAINMENT

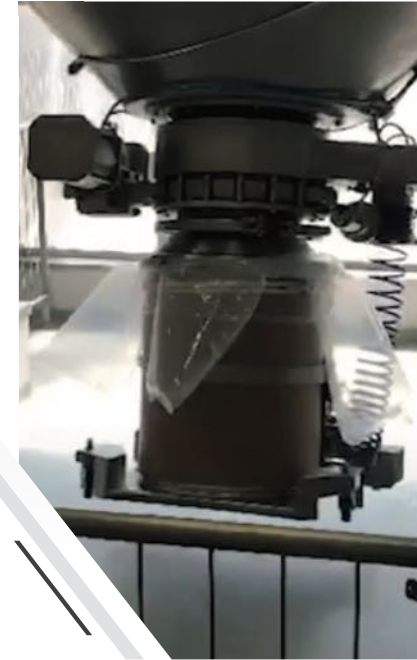
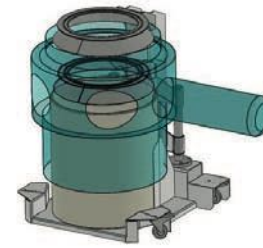

- CONTAINED DRUM INTERFACING
- COLLAPSABLE DRUM FLEXIBLE ISOLATOR
- LIFTING UP/DOWN TROLLEY
- STUB BAG OUT VIA CONTINUOUS LINER

OPEN BOTTOM EQUIPMENT CONTAINMENT

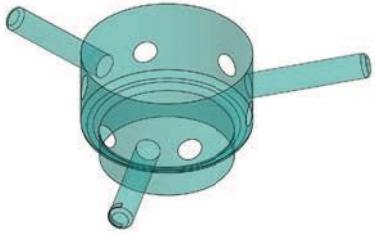

- CAKE RECOVERY
- CONTAINED DECONTAMINATION
- 3D SCANNING PROFILE
- COLLAPSABLE ISOLATOR

VALVE GASKET SEATS CONTAINMENT

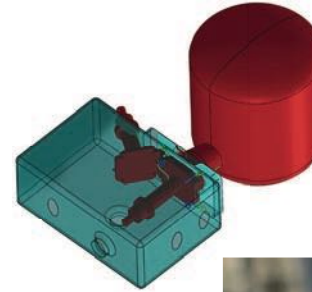

- CAKE RECOVERY
- CONTAINED GASKET SEATS CLEANING
- 3D SCANNING PROFILE
- COLLAPSABLE ISOLATOR

TRAY/FREEZE DRYER CONTAINMENT

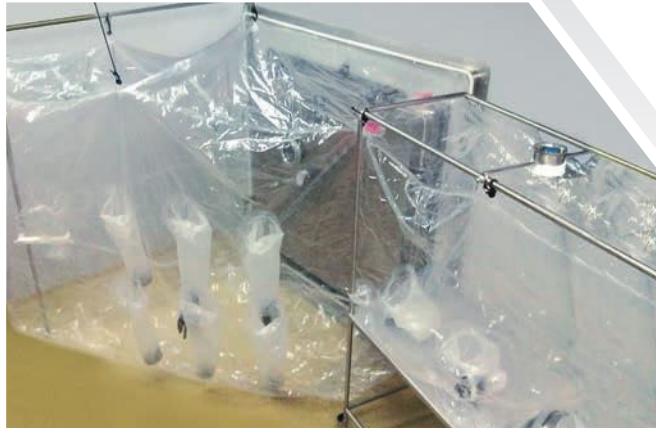

- CONTAINED LOADING AND OFFLOADING OPERATIONS
- IN LINE DISPENSING
- IN LINE SAMPLING
- IN LINE MILLING
- N₂ INERTIZATION OF THE SYSTEM AVAILABLE

DRUM TRANSFER SKID

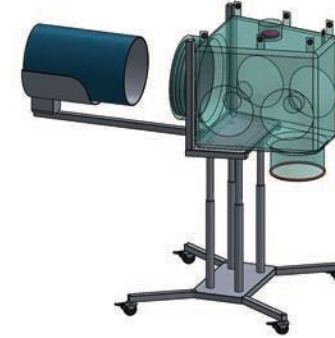

- MOVABLE & TELESCOPIC
- CONTAINED DRUM TRANSFER OPERATIONS
- BAG OUT WASTE BY CONTINUOUS LINER ON THE FREE SIDE GLOVE PORT

COATING MACHINE CONTAINMENT



- CONTAINED LOADING AND OFFLOADING
- CONTAINED SAMPLING
- IMPROVED OPERATOR ERGONOMICS

ON LINE MILLING (WEIGHING & SAMPLING)

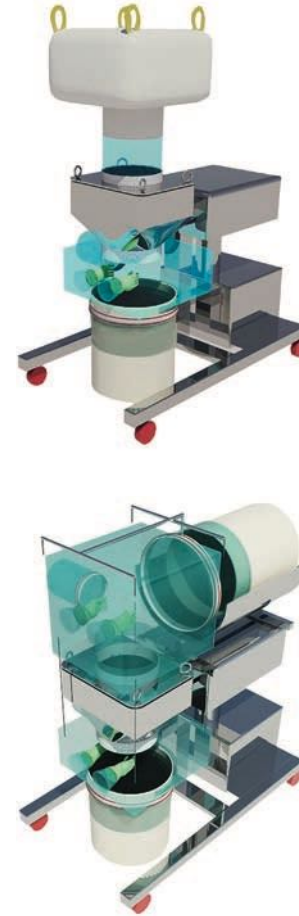

- CONTAINED LOADING AND OFFLOADING
- SAMPLING ON LINE OPTION AVAILABLE
- IN LINE WEIGHING AND WEIGHT CORRECTION
- N₂ INERTIZATION OF THE SYSTEM AVAILABLE
- IMPROVED OPERATOR ERGONOMICS

CLEAN MOBILE INTERFACE



- CLEAN ROOM INTERFACE FOR LOCAL GMP GRADE & HUMIDITY CONTROL
- N₂ OR FILTERED AIR INJECTION AVAILABLE
- DOSING BY IRIS VALVE
- COLLAPSIBLE STRUCTURE

IBC SAMPLING



- APPLICABLE TO REACTOR MANWAY, VALVE & FLANGE
- FOR CONTAINED, GMP & HUMIDITY CONTROLLED APPLICATIONS
- REMOVABLE TO BE USED AS TEMPORARY BUBBLE BARRIER
- EASY TO INSTALL AND REMOVE
- COLLAPSIBLE
- N₂ INERTIZATION OF THE SYSTEM AVAILABLE
- DOES NOT REQUIRE SAMPLING DEVICES

WASHING PARTS FLEXIBLE ISOLATOR

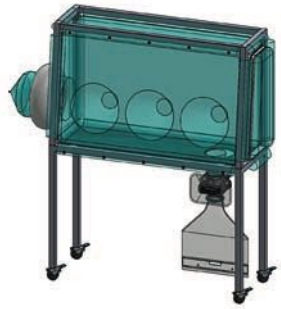

- MOVABLE PLUG AND PLAY SKID
- BAGGED PARTS ZIPPERED DOOR WAY IN
- RINSE FLUIDS COLLECTED INTO A BOTTOM CONTAINER
WASTE CONTAINED SEPARATION
- SPRAY GUN SUPPLY BY QUICK PROCESS CONNECTION

WASHING MACHINE LOADING CONTAINMENT

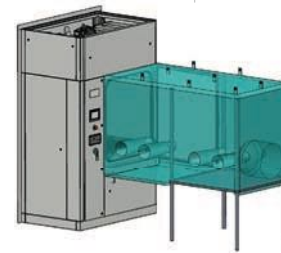

- MOVABLE PLUG AND PLAY SKID
- BAGGED PARTS ZIPPERED DOOR WAY IN
- WASTE BAG OUT VIA CONTINUOU LINER
AND CONTAINED SEPARATION

IN LINE POWDER SAMPLER

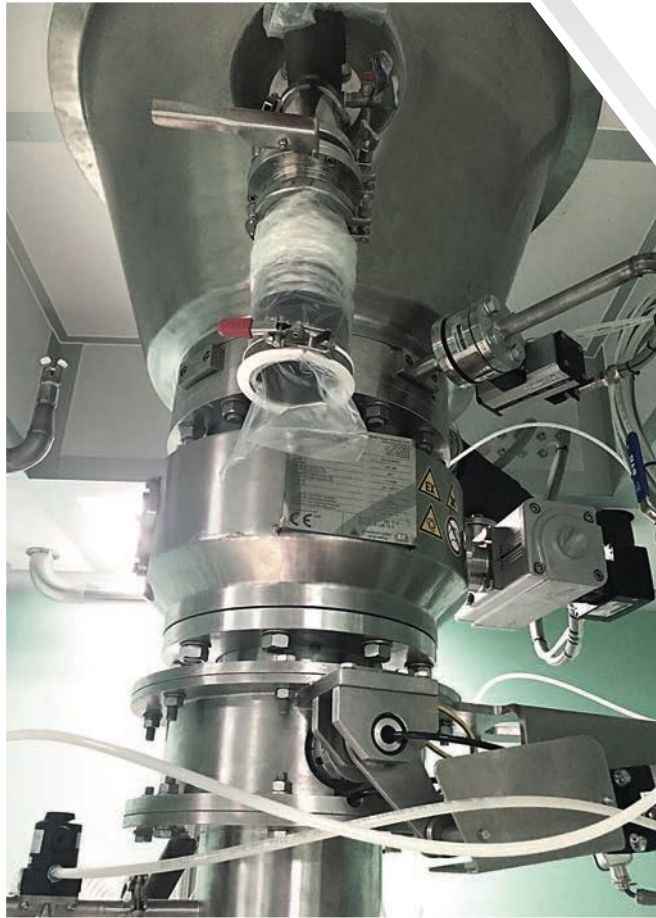

- CUT OFF MANUAL VALVE
- SAMPLES INTO 4" DIAMETER LINER OR ANY OTHER CONTAINER
- EASY TO DISMOUNT (NO TOOLS NEEDED)

GLOVE BOX DISCHARGE & SAMPLING



- CONTAINED OFFLOADING & SAMPLING INTO CONTINUOUS LINERS
- N₂ INERTIZATION AVAILABLE
- ON LINE WEIGHING & DOSING OPTIONS AVAILABLE
- DRUM LINER CONTAINED SEPARATION BY CRIMPING

DOUBLE CHAMBER PREP CHARGING



THE DOUBLE CHAMBER CHARGING ISOFLEX FEATURES:

- MOBILE AND TELESCOPIC
- ZIPPERED TRANSFER-IN PRE-CHAMBER
- WASTE BAG OUT LINER
- CLOSED BOTTOM
- CLAMP CHARGING CONNECTION
- N2 INJECTION, SPRAY GUN
- EASY TO INSTALL AND TO BE COLLAPSED FOR INCINERATION

COAXIAL CONTAINMENT DISCHARGING SKID

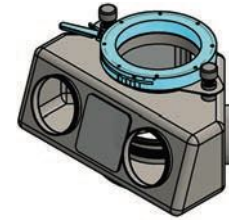

SKID FEATURE

- DOUBLE LINERS FOR OEB5 CONTAINMENT LEVEL
- SUITABLE FOR VERY SHORT OFFLOADING SPACE
- CLAMP FAST CONNECTION
- N2 INJECTION & SPRAY GUN
- PLUG AND PLAY INSTALLATION ON EXISTING EQUIPMENT

TRIPLE CHAMBER FREEZE DRIER FLEXIBLE ISOLATOR



- ZIPPERED DOORS
- PRODUCT AND WASTE BAG OUT VIA SLIDING LINER
- DIFFERENTIAL PRESSURE CASCADE
- QUICK SNAPS INSTALLATION
- SWINGING ERGONOMIC WORKING BENCH

SAFE CHANGE FILTERS BATTERY SKID

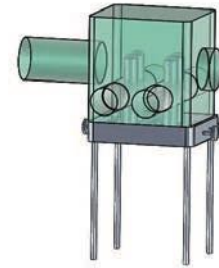

- SAFE CHANGE FILTERS
- BAG-IN & BAG-OUT INTERFACE
- SPRAY GUN DECONTAMINATION
- AVAILBLE UNDER N2 ATMOSPHERE

DRUM TO DRUM WEIGHING ADJUSTMENT STATION

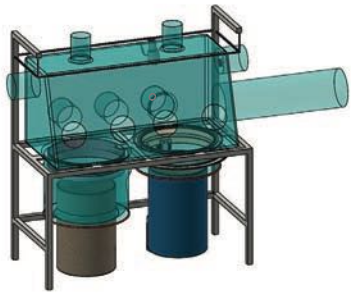

- HIGH CONTAINMENT DRUM INTERFACE
- PNEUMATIC VERTICAL LIFTING/SLIDING DRUM CANISTERS
- WASTE BAG OUT VIA CONTINUOUS LINER
- NO STEEL SURFACE PRODUCT CONTACT
- BUNGEE CHORDS INSTALLATION
- OUTER FLOOR SCALE WEIGHING NOT ACCURACY AFFECTED BY THE ENCLOSURE

IN LINE LIQUID DRUM CHARGING

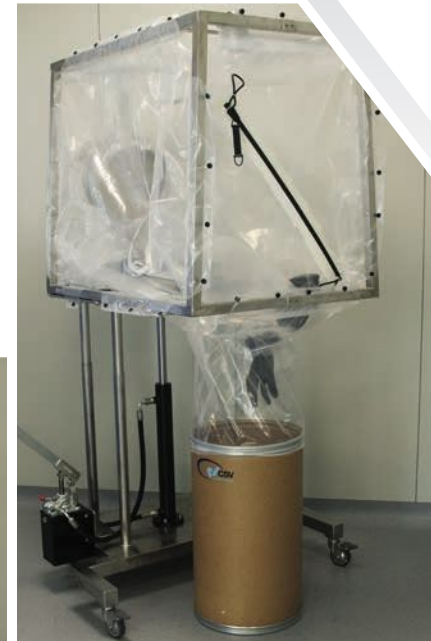
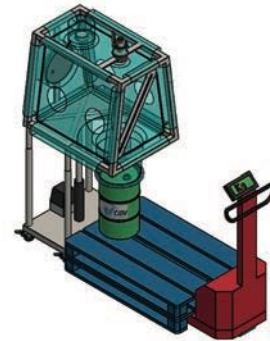

- LIQUID CHARGING TROUGH THE WALL MANIFOLD
- DIRECT DRUM WEIGHING ON PALLET

MANUAL BAG LIFTER

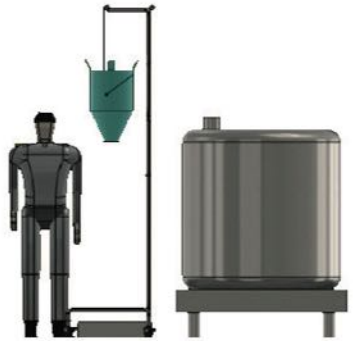

- COMPACT AND MOVABLE
- DOUBLE DIRECTION
- SS 316 L
- 50 KG MAX LOAD

MANUAL DRUM LIFTER



- COMPACT AND MOVABLE
- DUAL USE
- STEEL MADE
- ROUNDED CORNER
- 125 KG CAPACITY

CENTRIFUGE SCOOPING OUT CANOPY

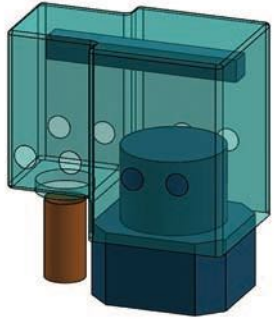

- CENTRIFUGE CANOPY
- NOT EXPOSED SCOOPING OUT OPERATIONS
- N2 ATMOSPHERE

PLASTIC ISOLATOR

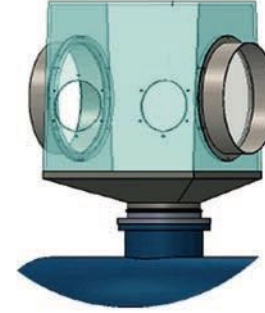

- COMPACT AND MOVABLE
- BAG IN BAG OUT VIA CONTINUOUS LINER OR SLEEVE
- AVAILABLE IN TWO CHAMBER OPTIONS WITH PASS BOX

INFLATION TESTING

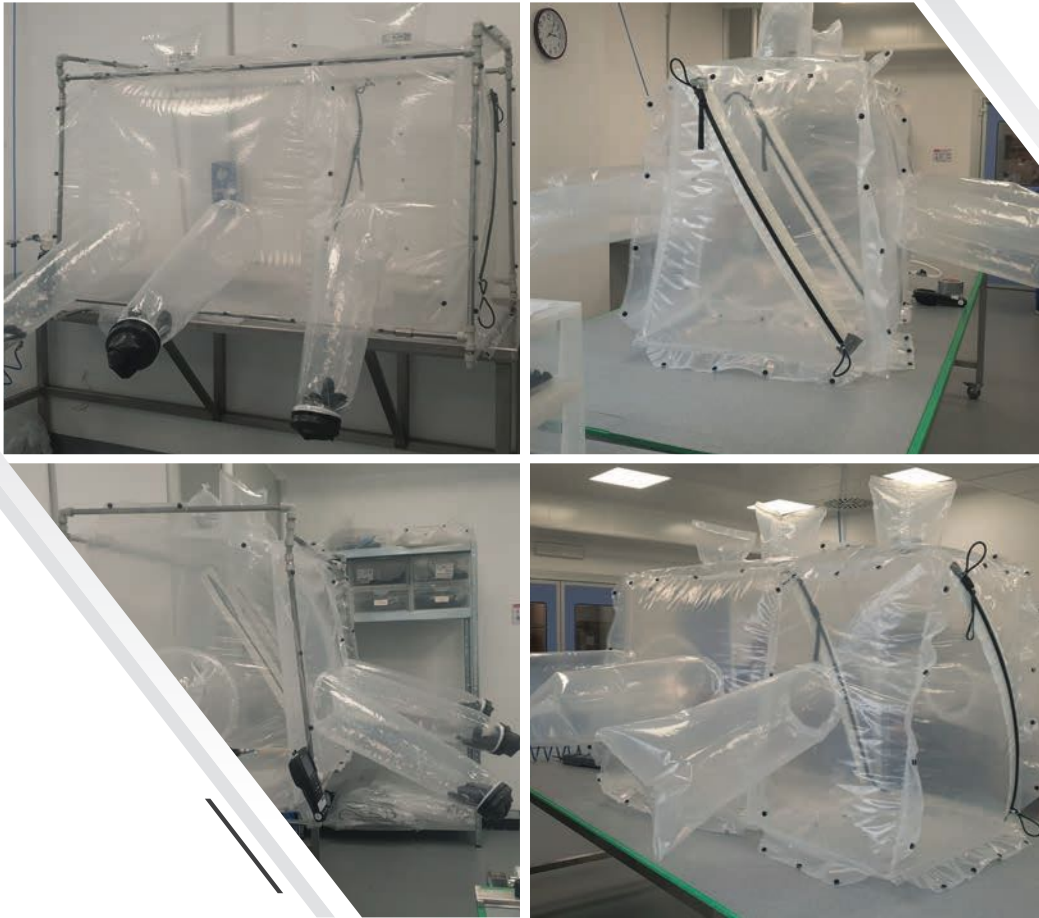

- IN FACTORY, PRIOR DELIVERY, INFLATION TESTING
- IN SITE INFLATION TESTING

CONTAINMENT PERFORMANCES SMEPAC MONITORING

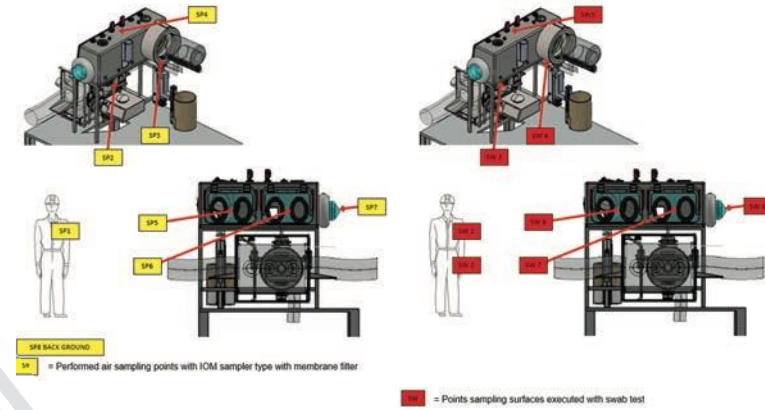
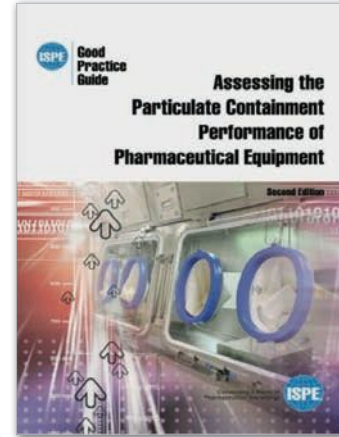

SITE MOCK UP



- SITE REAL TIME MOCK UP
- NOT INVASIVE ACTIVITY
- FAST REALIZATION
- PERFECT OPERATIONS MIMING
- FINAL OWNERS/OPERATORS INVOLVMENT
- IN ADVANCE MISTAKES AND CONSTRAINTS DISCOVERY
- EXPRESS DESIGN

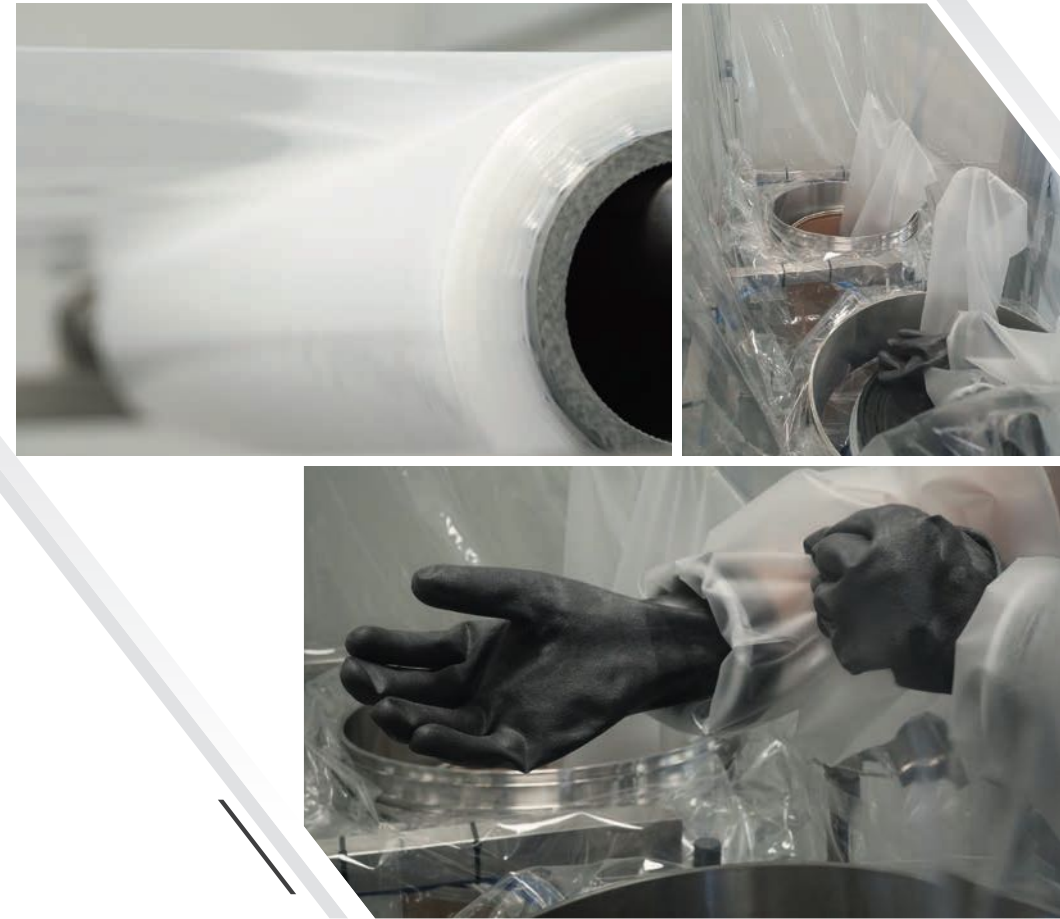

- FILM AT A GLANCE
- LOW DENSITY POLYETHYLENE OR POLYURETHANE
- TRANSPARENT AND SUPER- TRANSPARENT
- DISSIPATIVE
- NO SURFACE TREATMENT
- SOLVENTS & CHEMICALS RESISTANT



DRUM IRIS
TECHNOLOGY



*Certificate delivered by the European Commission,
as the institution managing Horizon 2020,
the EU Framework Programme for Research and Innovation 2014-2020*

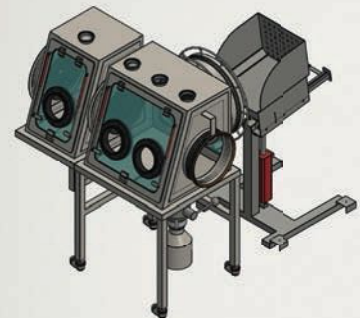

DOUBLE IRIS DISPENSING

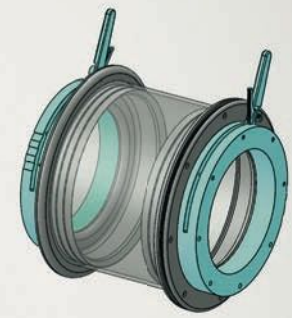

DOUBLE IRIS PASS BOX



PNEUMATIC SYSTEM IRIS INTERFACE



FIBC IRIS INTERFACE





Build Different

CSV LIFE SCIENCE

VIA SELVANESCO 75 - 20142 MILANO - ITALIA
www.csv-ls.com info@csv-ls.com
PHONE: +39 02 274393.1 FAX: +39 02 27439320
www.csvcontainmentnews.com



LUCA VIETRI

l.vietri@csv-ls.com

MOBILE: +39 335 7594 461

ANDREA PEDERZINI

a.pederzini@csv-ls.com

MOBILE: +39 335 59 11 943

ROBERTO FURLAN

r.furlan@csv-ls.com

MOBILE: +39 340 9777 631

