



**MIX S.r.l.**

MIXING SYSTEMS AND  
COMPONENTS FOR PLANTS

[www.mixitaly.com](http://www.mixitaly.com)

# Technical data sheet

Interception



 **ATEX RANGE AVAILABLE**

# Butterfly Valve Combination table



## Identification

- N: Standard
- A: Atex II 2/3D Ex h IIIB T100°C Db/Dc X

## Classification MSD

- ## Nominal diameter
- 100 - 150 - 200 - 250
  - 300 - 350 - 400

## Shaft

- A2: Square drive shaft  
ISO 5211
- C2: Splined drive shaft  
DIN 5482
- K2: Extended square drive shaft  
ISO 5211
- L2: Extended splined drive shaft  
DIN 5482

Fig.01

## Seal

- A: Standard powder seal in atmospheric pressure
- B: Seal tested to 0,2 bar over/under pressure  
(tested at ambient temperature)  
Note: SVA 350 - SVA 400 excluded

## Body of the valve always in aluminium alloy. Closing Disk and profile of the seal:

- 6: closing disk in aluminium alloy, low seal
- 7: closing disk in stainless steel AISI304, low seal
- 8: closing disk in stainless steel AISI304, high seal,  
covering the inside of the body and the flanges
- 9: closing disk in aluminium alloy, high seal, covering the inside of the body and the flanges

MATERIAL OF THE SEAL AND WORKING TEMPERATURES					
VERSION	MATERIAL	COLOR	PROFILE	STANDARD	ATEX
1	NBR	White	High / Low	-20°C / + 100°C	-20°C / + 100°C
2	NBR Certificate FDA		High	-20°C / + 100°C	
5	HNBR-THERBAN	Black	High / Low	-25°C / + 150°C*	
9	NBR Certificate 1935/2004**	White	High	-20°C / + 100°C	

\* Possibility of range -25°C / +230°C with specific construction solutions IL0945 applicable only for extended drive shaft versions and Viton seal

\*\* Valve with Declaration of conformity for food contact according to Regulations (EC) n. 1935/2004 and 2023/2006

Fig.01

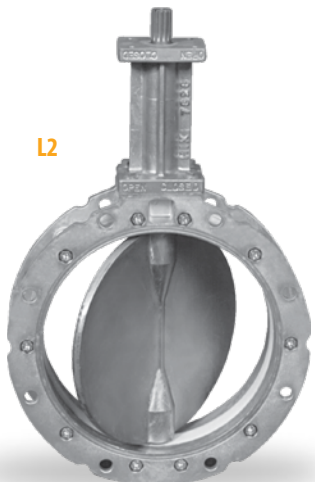
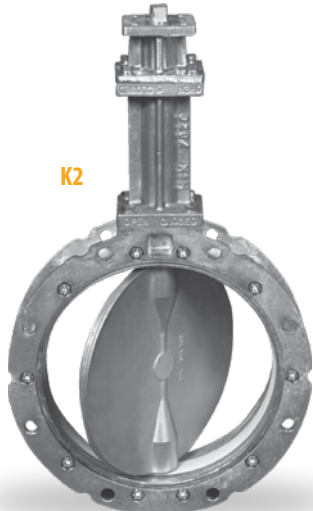
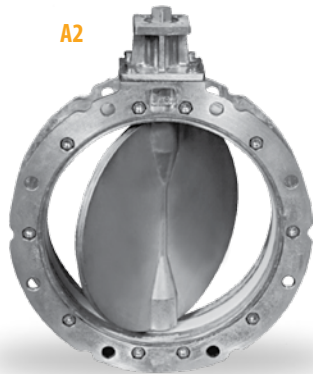

Seal only in the closing area of the disk "LOW"

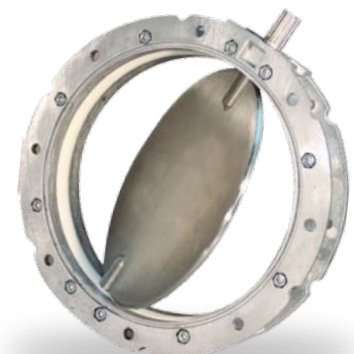

# Dimensions

## .-SVAH...A2... / .-SVAH...K2...

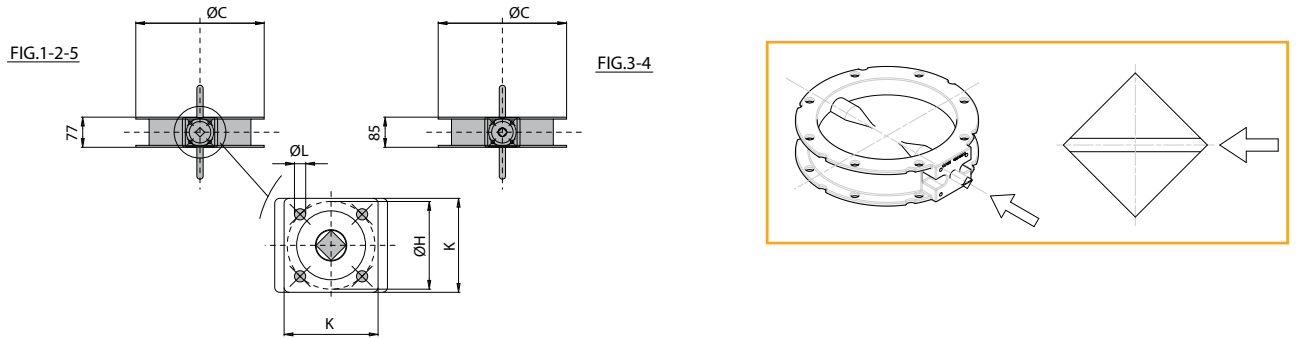

### Square drive shaft

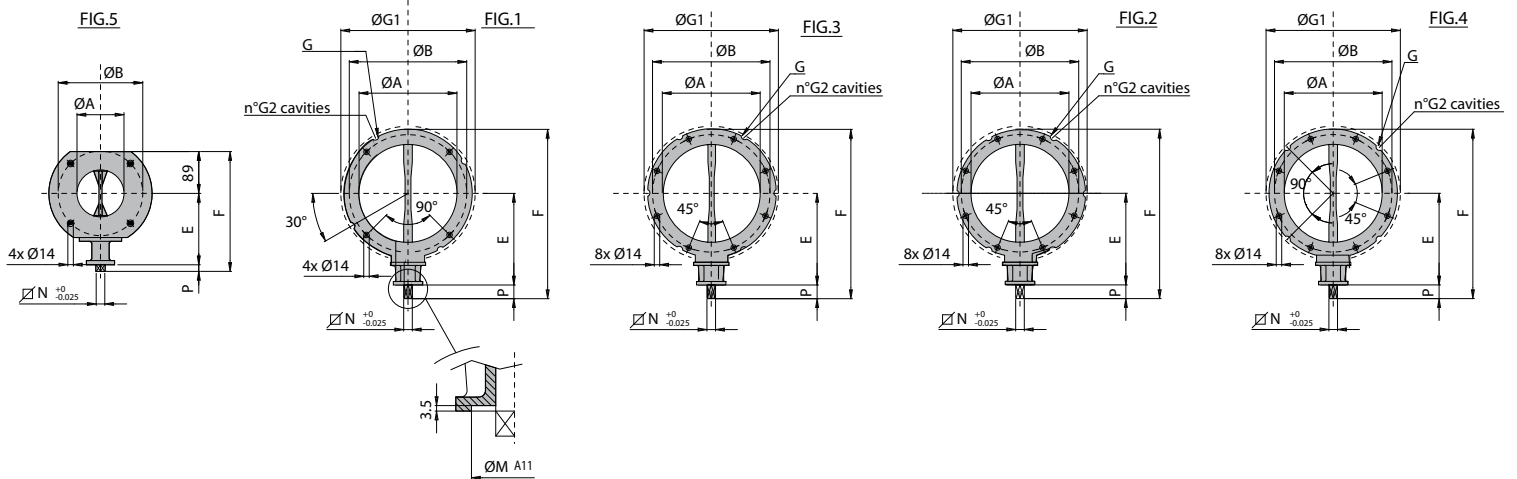

### Extended square drive shaft

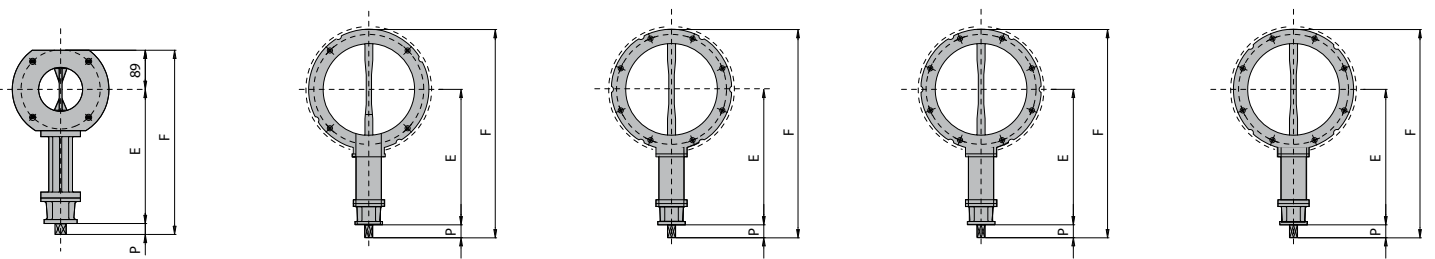

		.-SVAH...2...																A2...		K2...				
TYPE	Inch	mm	Fig.	ISO	A	B	C	G	G1	G2	PN	ND	H	K	L	M	N	P	E	F	kg	E	F	kg
.-SVAH100.2...	4"	100	5	F05	100	180	220	/	/	/	10	10	50	60	7	35	14	14	152	255	5	306	409	6,3
.-SVAH150.2...	6"	150	1	F07	150	200	228	9	225	4	6	6	70	75	9	55	17	16	177	307	5,5	331	461	6,8
.-SVAH200.2...	8"	200	1	F07	200	250	278	9	280	4	6	6	70	75	9	55	17	16	202	356	7,5	356	510	8,8
.-SVAH250.2...	10"	250	2	F07	250	300	328	9	335	6	6	6	70	75	9	55	17	16	227	406	8,5	381	560	9,8
.-SVAH300.2...	12"	300	2	F07	300	350	378	11	395	6	6	6	70	75	9	55	17	16	252	456	11,5	406	610	12,8
.-SVAH350.2...	14"	350	3	F10	350	400	440	11	445	6	6	6	102	105	11	70	22	25	289	534	20	489	735	21,8
.-SVAH400.2...	16"	400	4	F10	400	470	530	12,5	515	4	10	10	102	105	11	70	22	25	314	604	23	514	804	24,8

# Dimensions

## .-SVAH...C2... / .-SVAH...L2...

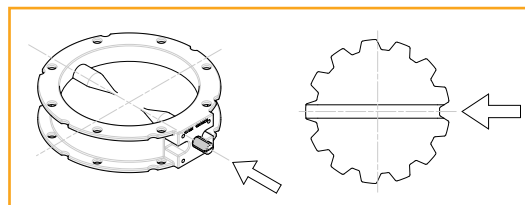
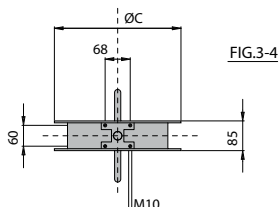
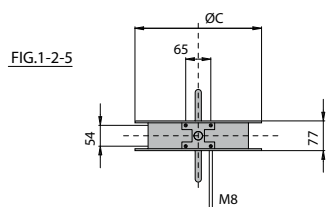

### Spined drive shaft

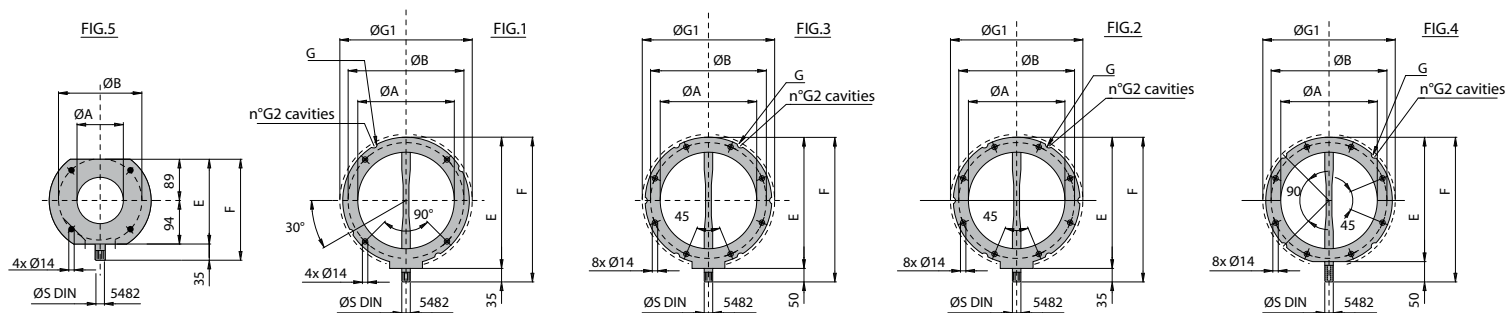

### Extended spined drive shaft

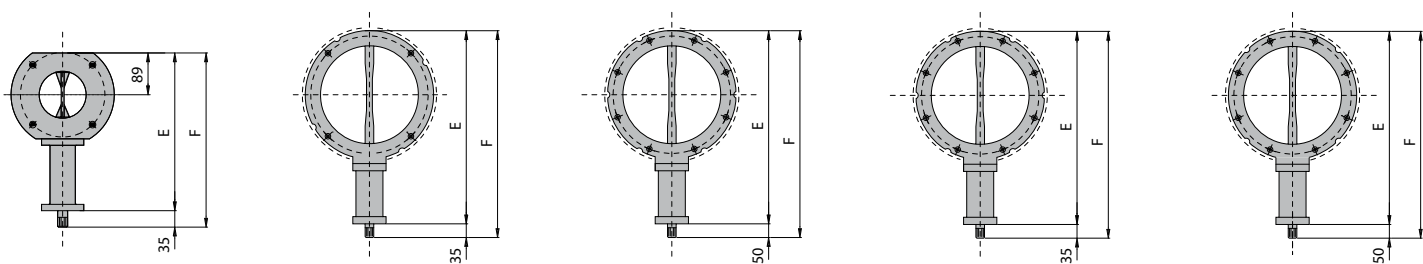

			.-SVAH...2...										C2...		L2...			
TYPE	Inch	mm	Fig.	A	B	C	G	G1	G2	PN	ND	S	E	F	kg	E	F	kg
.-SVAH100.2...	4"	100	5	100	180	220	/	/	/	PN10	ND10	22x19	183	218	4,5	337	372	5,8
.-SVAH150.2...	6"	150	1	150	200	228	9	225	4	PN6	ND6	22x19	233	268	5	387	422	6,3
.-SVAH200.2...	8"	200	1	200	250	278	9	280	4	PN6	ND6	22x19	282	317	7	436	471	8,3
.-SVAH250.2...	10"	250	2	250	300	328	9	335	6	PN6	ND6	22x19	332	367	8	486	521	9,3
.-SVAH300.2...	12"	300	2	300	350	378	11	395	6	PN6	ND6	22x19	382	417	11	536	571	12,3
.-SVAH350.2...	14"	350	3	350	400	440	11	445	6	PN6	ND6	28x25	439	489	20	639	689	22,3
.-SVAH400.2...	16"	400	4	400	470	530	12,5	515	4	PN10	ND10	28x25	509	559	23	709	759	25,4



# Accessories Butterfly Valve

## SLEEVE FOR FLEXIBLE CONNECTION - SFU

**SFU**



**B**



Round flange

**Nominal diameter**  
100 - 150 - 200 - 250  
300 - 350 - 400

**Construction material**  
2 = Stainless steel AISI 304  
8 = Aluminium

INTERNAL ASSEMBLY CODE MIX	
HAS10	SFU with .-SVAH100÷200
HAS20	SFU with .-SVAH250÷400

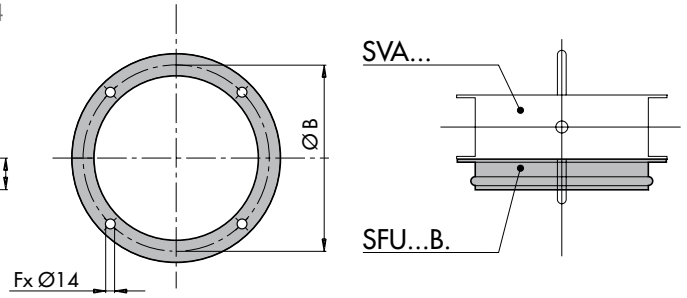
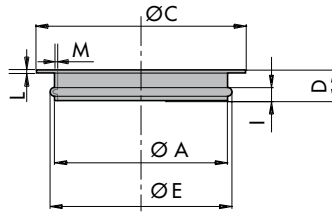

Type	Inch	ØA	ØB	ØC	D	ØE	F	I	L	M	kg
SFU100B2	4"	100	180	220	46	106	4	18	4	2	1,1
SFU150B2	6"	150	200	225	46	156	4	18	8	2	1,6
SFU200B2	8"	200	250	275	46	206	4	18	8	2	2,1
SFU250B2	10"	250	300	325	46	256	8	18	8	2	2,6
SFU300B2	12"	300	350	375	46	306	8	18	8	2	3,0
SFU350B2	14"	350	400	436	50	356	8	18	8	2	4,0
SFU400B2	16"	400	470	525	50	406	8	18	10	2	7,9

Type	ØA	ØB	ØC	D	ØE	F	I	L	M	kg
SFU100B8	110	180	220	48	125	4	12	2,5	2,5	0,5
SFU150B8	164	200	228	48	178	4	12	2,5	2,5	0,6
SFU200B8	210	250	278	48	223	4	12	2,5	2,5	0,7
SFU250B8	265	300	328	48	275	8	12	2,5	2,5	1,1
SFU300B8	315	350	378	48	328	8	12	2,5	2,5	1,3
SFU350B8	354	400	440	53	356	8	12	3	3	1,9
SFU400B8	404	470	530	53	417	8	12	3	3	2,7

## FLANGE - KFT

**KFT**



Flange

**Nominal diameter**  
100 - 150 - 175 - 200  
250 - 300 - 350 - 400

**Construction material**  
1 = Carbon steel  
2 = Stainless steel AISI 304

**KFT...A.**

Type	Ø A	Ø B	Ø C	D	kg
* KFT100A1	116	180	220	6	1,29
* KFT100A2	116	180	220	4	0,86
KFT150A.	170	200	228	6	0,85
KFT175A.	195	250	278	8	1,94
KFT200A.	221	250	278	6	1,05
KFT250A.	275	300	328	6	1,18
KFT300A.	325	350	378	6	1,38

**KFT...C.**

Type	Ø A	Ø B	Ø C	D	kg
* KFT100C1	103	180	220	6	1,40
* KFT100C2	103	180	220	4	0,93
KFT150C.	155	200	228	6	1,03
KFT200C.	205	250	278	6	1,30
KFT250C.	256	300	328	6	1,56
KFT300C.	305	350	378	6	1,84
KFT350C.	358	400	440	6	2,42
KFT400C.	409	470	530	10	7,01

**KFT....**

x F	SVA
4	100
4	150
4	200
8	250
8	300
8	350
8	400

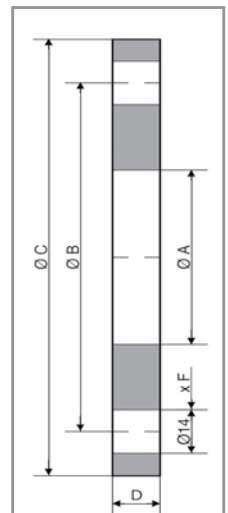

# Actuators Butterfly Valve

## RAB



## C

TYPE	A	B	C	D	kg	SVA
RAB22C	65	27	8,5	22 X 18 DIN 5482	1,7	100 - 300
RAB28C	68	30	10,5	28 X 25 DIN 5482	2	350 - 400

Manual actuator

Size  
22 - 28

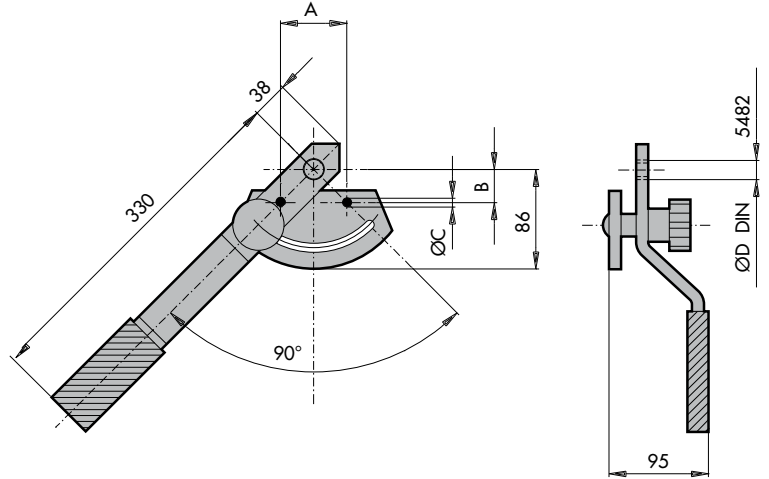
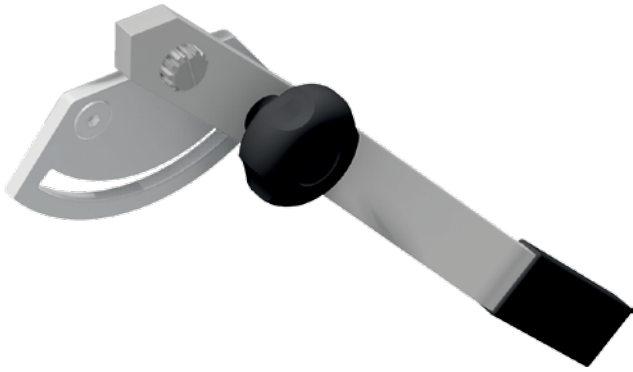

## RAM



## C



## N

INTERNAL ASSEMBLY CODE MIX	
HAM10	RAM with SVAH100 ÷ 400

Size  
22 - 28

Qty of limit switches mod. FR515

- 2: limit switch
- 3: limit switch

Geared motor actuator

Only available for NON-ATEX version

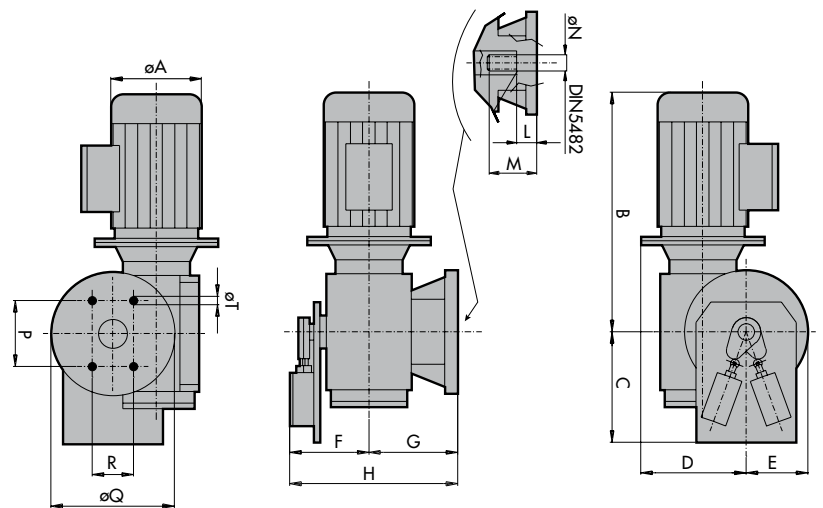
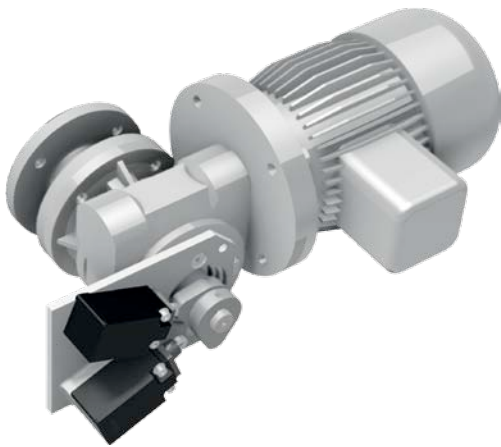

TYPE	A	B	C	D	E	F	G	H	L	M	N	P	Q	R	T	kW	Nm*	kg	SVA
RAM22C.N	125	255	115	115	55	95	110	205	16	37	22X19 DIN 5482	65	110	54	8,5	0,20	100	10	100÷300
RAM28C.N	140	300	115	120	70	105	120	225	16	37	28X25 DIN 5482	68	120	60	10,5	0,37	150	18	350÷400

\* The torque value refers to the available starting torque for a maximum duration of 2".

# RAP

# C



**Double acting  
pneumatic actuator**

**Cylinder diameter  
080 - 100 - 125**

**Cover  
A: high  
B: low**

**Conditions of sale  
P: Packed singularly  
M: mounted to the -SVA\*  
\*see p.9**

**Identification**

**N:** Standard  
**A:** Atex II 3D Ex h IIIB T100°C Dc X

**Shaft coupling**

**S:** ISO 5211 square drive coupling  
**X:** DIN 5482 splined drive coupling

COMBINATION TABLE	
<b>ISO 5211</b>	<b>DIN 5482</b>
.-RAPC080S.	.-RAPC080X.
.-RAPC100S.	.-RAPC100X.
	.-RAPC125XA.

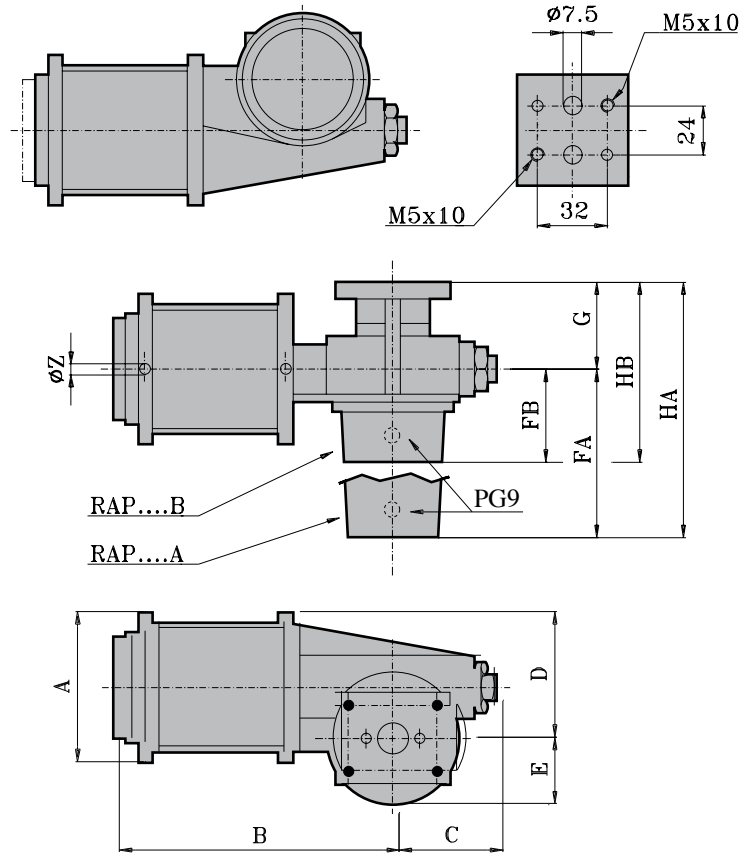
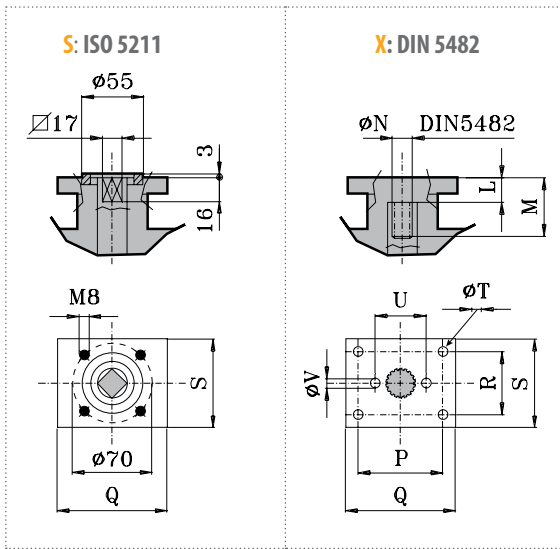

TYPE	Air consumption for operation	Operation time @ 6 bar
.-RAPC080	1,8 NI	~ 0,5 s
.-RAPC100	2,8 NI	
.-RAPC125	7,6 NI	

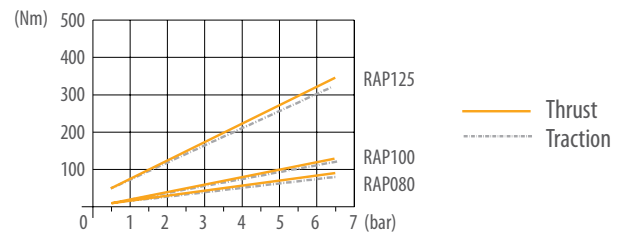

TYPE	A	B	C	D	E	FA	FB	G	HA	HB	L	M	N	P	Q	R	S	T	U	V	Z	kg	SVA
.-RAPC080	90	200	100	84	58	150	75	62	212	137	19	37	22X19 DIN 5482	65	90	54	75	9	50	11	1/8"	3,5	100÷300
.-RAPC100	110	210	100	94	58	150	75	62	212	137	19	37	22X19 DIN 5482	65	90	54	75	9	50	11	1/8"	4,5	300
.-RAPC125	137	275	170	124	72	165	90	96,5	262	187	20	52	28X25 DIN 5482	68	106	60	84	10,5	/	/	1/4"	10	350÷400



# Accessories for actuators

## LIMIT SWITCH

The transparent cover of the limit switches allows to check the position of the actuator (OPEN - CLOSED) from outside.

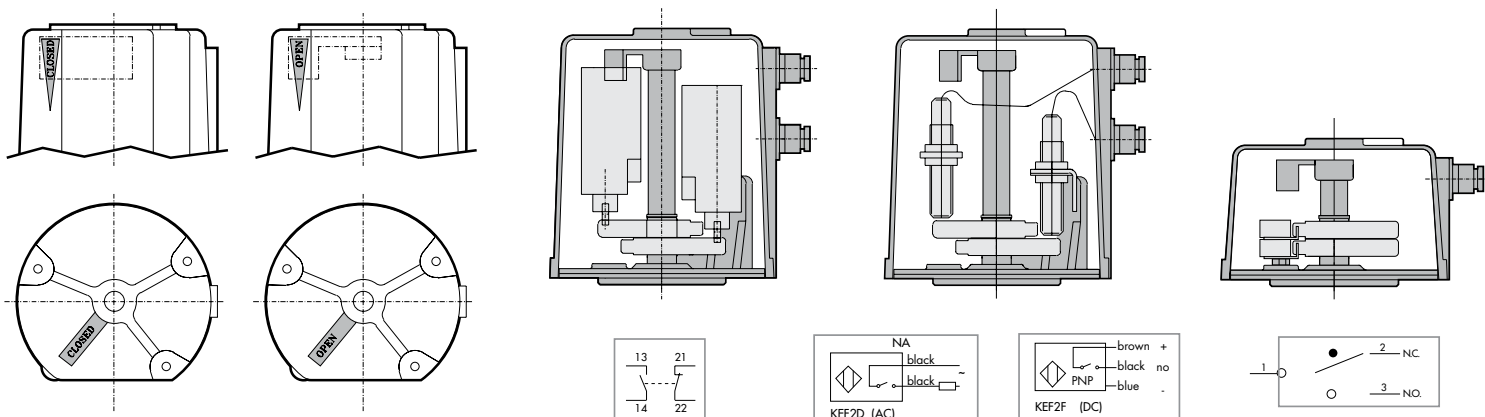

	MECHANICS	INDUCTIVE		MICRO MECHANICS
STANDARD	KEF2C	KEF2D	KEF2F	KEF2E
ATEX	KEH2C	KEH2D	KEH2F	KEH2E*
VOLTAGE	6A - 120V ÷ 3A - 400V AC 2,5A - 24V ÷ 0,25A - 250V DC	20V ÷ 240V AC	5V ÷ 40V DC Type PNP	6A - 125V ÷ 250V AC 6A - 30V DC
SUPPLY (fixing hardware included)				

\* only available for A-RAP...XB

## ELECTRO-VALVE



### Identification

- /: Standard (without silencers)
- A: ATEX (including 2 silencers)
- II 2G Ex h IIB T5 Gb
- II 2D Ex h IIIC T100°C Db

### Type

- C = in line
- D = namur

### Dimension

- 4 = 1/4"
- 8 = 1/8"

### Actuator

- 1 = RAPC080
- RAPC100
- 4 = RAPC125

### Type

- C = Standard
- D = ATEX

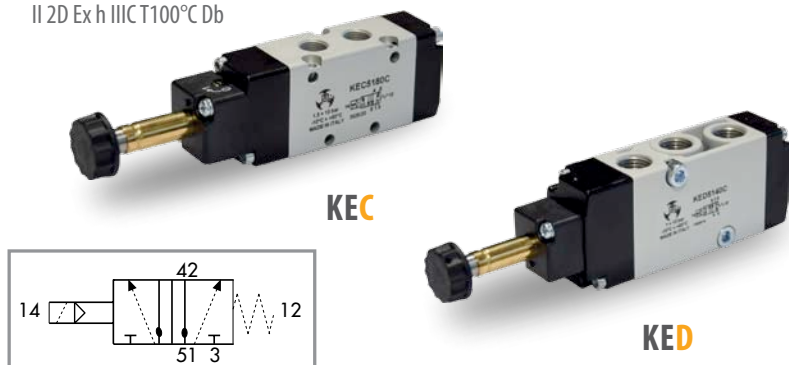
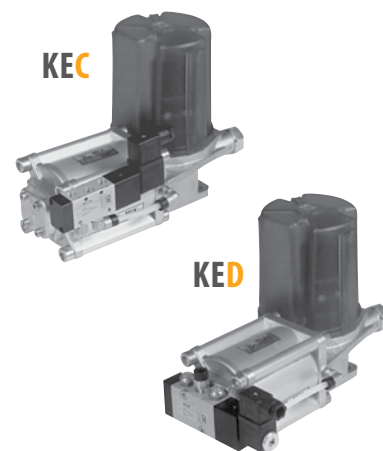

### COMBINATION TABLE

.-RAP	STANDARD	ATEX
080	KEC 5181C - KED 5141C	A-KEC 5181D - A-KED 5141D
100	KEC 5181C - KED 5141C	A-KEC 5181D - A-KED 5141D
125	KEC 5144C - KED 5144C	A-KEC 5144D - A-KED 5144D

Monostabile electro-valve - 5 ways - spring device



## SILENCER STD

# 70H3H24

### TYPE

- 1 = KEC5181 - 1/8"
- 3 = KEC5144 - 1/4"
- KED5141 - 1/4"
- KED5144 - 1/4"



## SOLENOID COIL

# KEB

# 3

### Voltage

- 024 = 24 V
- 048 = 48 V
- 115 = 115 V
- 230 = 230 V

### Frequency

- DC: Direct current DC
- AC: Alternating current AC 50/60 Hz

### COMBINATION TABLE

KEB 024 DC 3	KEB 024 AC 3
KEB 048 DC 3	KEB 048 AC 3
	KEB 115 AC 3
	KEB 230 AC 3

## SOLENOID COIL ATEX\*

CODE	POWER SUPPLY	PROTECTION LEVEL	CERTIFICATION
12A01358	24V DC	IP65	II 3G Ex nA IIC Tx Gc II 3D Ex tc IIIC Tx Dc
12A01352	24V AC		
12A01354	115V AC		



\* suitable for conductive and non-conductive powders

## ASSEMBLY IN MIX

STANDARD	ATEX	INTERNAL ASSEMBLY CODE MIX
HAR10	A-HAR10	.-RAP 80 ÷ 100 with .-SVAH100 ÷ 300
HAR20	A-HAR20	.-RAP125 with .-SVAH350 ÷ 400
HAE10	A-HAE10	Electro-valve .-KEC in line with .-RAP
HAE20	A-HAE20	Electro-valve .-KED Namur with .-RAP
HAF10	A-HAF10	Mechanical limit switch with .-RAP
HAF20	A-HAF20	Inductive limit switch with .-RAP
HAF30	A-HAF30	Micro limit switch with .-RAP

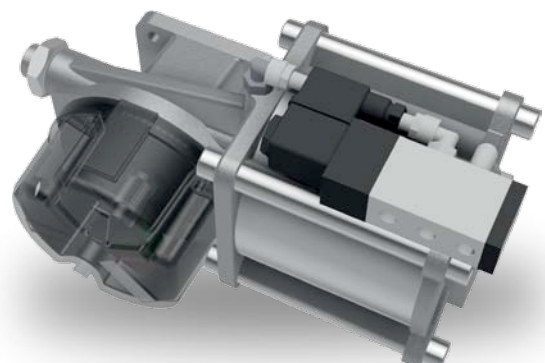
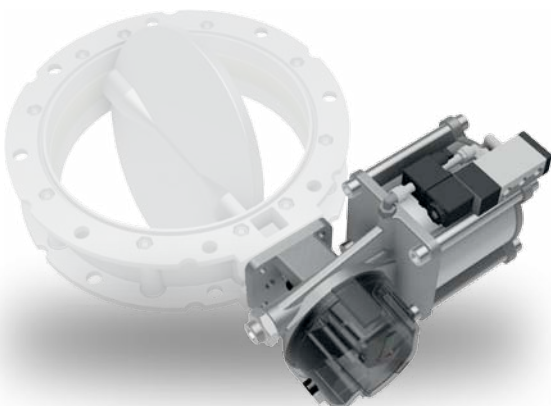

# Slide Valves Combination table



Handling screw

Size  $\varnothing$   
 150 - 200 - 250 - 300 - 350  
 400 - 500 - 600 - 700 - 800

Construction material  
 1: Carbon steel  
 2: Stainless steel AISI 304

Classification MSD  
 H: partly finished machinery  
 E: not machinery

## Identification

- N: Standard
- A: ATEX II 2/3D Ex h IIIB T135°C Db/Dc X  
(marking for version with motor M)
- T: Version suitable for explosive atmosphere  
(for versions with bare shaft A and handwheel V)

ACTUATOR COMBINATION TABLE			
A	free	00	Bare Shaft
V	manual handwheel	20	SGAE150 ÷ 350
		25	SGAE400 ÷ 800
M	gear motor	04	SGAH150 ÷ 350 = 0,37kW 230/400V 50Hz IP55 CL F
		08	SGAH400 ÷ 800 = 0,75kW 230/400V 50Hz IP55 CL F

Abb.01

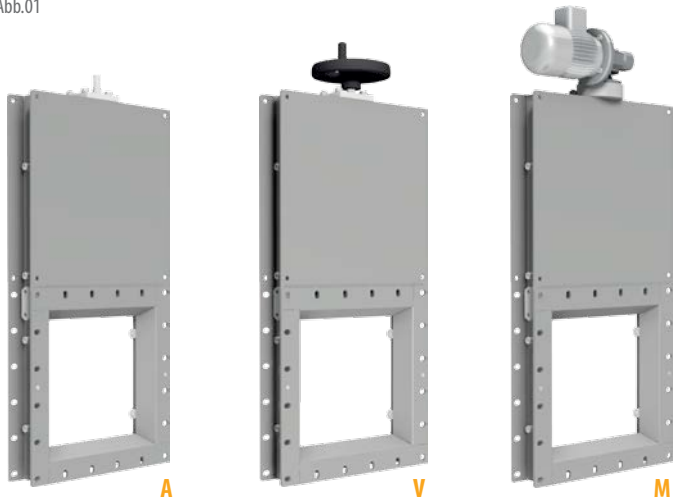

COMBINATION TABLE		
.-SGAE150A.A00	.-SGAE150A.V20	.-SGAH150A.M04
.-SGAE200A.A00	.-SGAE200A.V20	.-SGAH200A.M04
.-SGAE250A.A00	.-SGAE250A.V20	.-SGAH250A.M04
.-SGAE300A.A00	.-SGAE300A.V20	.-SGAH300A.M04
.-SGAE350A.A00	.-SGAE350A.V20	.-SGAH350A.M04
.-SGAE400A.A00	.-SGAE400A.V25	.-SGAH400A.M08
.-SGAE500A.A00	.-SGAE500A.V25	.-SGAH500A.M08
.-SGAE600A.A00	.-SGAE600A.V25	.-SGAH600A.M08
.-SGAE700A.A00	.-SGAE700A.V25	.-SGAH700A.M08
.-SGAE800A.A00	.-SGAE800A.V25	.-SGAH800A.M08



## Identification

- N: Standard
- A: ATEX II 2/3D Ex h IIIB T135°C Db/Dc X

Pneumatic cylinder

Size  $\varnothing$   
 150 - 200 - 250 - 300 - 350  
 400 - 500 - 600 - 700 - 800

Construction material  
 1: Carbon steel  
 2: Stainless steel AISI 304

Cylinder size  
 063:  $\varnothing$  63  
 080:  $\varnothing$  80  
 100:  $\varnothing$  100  
 125:  $\varnothing$  125

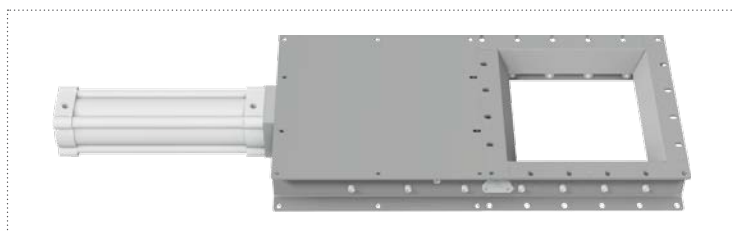

COMBINATION TABLE			
Small series		Big series	
.-SGBH150A.063	/	.-SGBH400A.100	.-SGBH400A.125
.-SGBH200A.063	/	.-SGBH500A.100	.-SGBH500A.125
.-SGBH250A.063	.-SGBH250A.080	.-SGBH600A.100	.-SGBH600A.125
.-SGBH300A.063	.-SGBH300A.080	.-SGBH700A.100	.-SGBH700A.125
.-SGBH350A.063	.-SGBH350A.080	.-SGBH800A.100	.-SGBH800A.125

# Dimensions

.-SGA...A.A../.-SGA...A.V../.-SGA...A.M..

Bare shaft

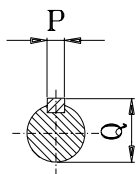

Manual control

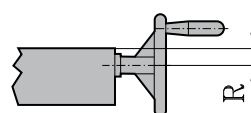

Motor Control

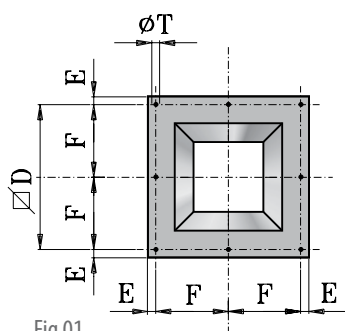
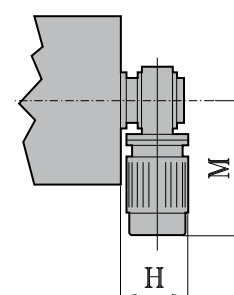
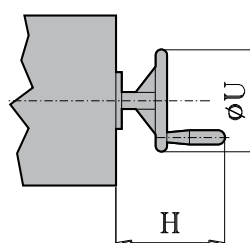
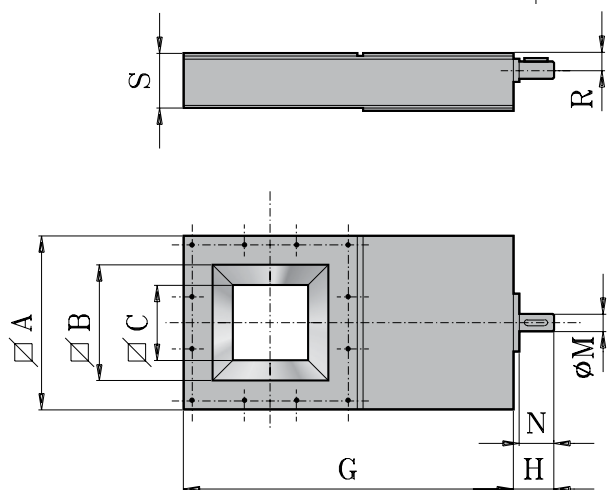
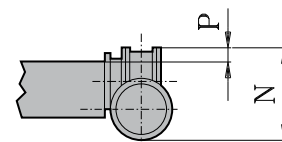

Fig.01

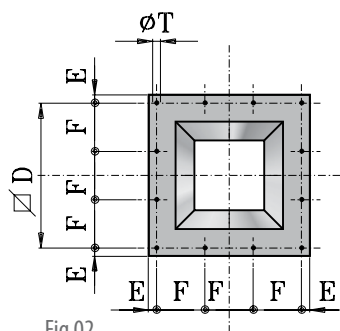

Fig.02

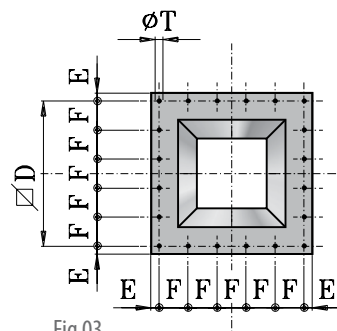

Fig.03

		.-SGA....A.										A..					V..				M..							
TYPE	Fig.	A	B	C	D	E	F	G	S	T	H	M	N	P	Q	R	kg	H	R	U	kg	H	M	N	P	kW	*	kg
.-SGA.150A....	1	261	175	120	230	15,5	115	540	93	12,5	56	19	41	6	21,5	30	16	150	30	200	18,8	180	300	200	30	0,37	19	24
.-SGA.200A....	2	311	225	170	280	15,5	93,3	640	93	12,5	56	19	41	6	21,5	30	19	150	30	200	22,5	180	300	200	30	0,37	26	27
.-SGA.250A....	2	361	275	220	330	15,5	110	740	93	12,5	56	19	41	6	21,5	30	25,5	150	30	200	27,5	180	300	200	30	0,37	32	32
.-SGA.300A....	2	431	325	270	385	23	128,3	860	93	12,5	56	19	41	6	21,5	30	32,5	150	30	200	35	180	300	200	30	0,37	39	39
.-SGA.350A....	3	481	375	320	445	18	89	960	93	12,5	56	19	41	6	21,5	30	38,5	150	30	200	42	180	300	200	30	0,37	45	52
.-SGA.400A....	3	533	425	350	500	16,5	100	1090	133	12,5	85	24	41	8	27	45	62,5	190	45	250	69,5	220	340	225	30	0,75	43	96
.-SGA.500A....	3	653	525	450	600	26,5	120	1300	133	15	85	24	41	8	27	45	85	190	45	250	92	220	340	225	30	0,75	54	128
.-SGA.600A....	3	753	625	550	700	26,5	140	1500	133	15	85	24	41	8	27	45	117	190	45	250	125	220	340	225	30	0,75	65	143
.-SGA.700A....	3	895	725	650	825	35	165	1720	133	15	85	24	41	8	27	45	147	190	45	250	150	220	340	225	30	0,75	75	173
.-SGA.800A....	3	995	825	750	925	35	185	1920	133	15	85	24	41	8	27	45	192	190	45	250	195	220	340	225	30	0,75	86	218

\* Duration in seconds for one single opening or closing



# Dimensions

## .-SGB...A....

### Pneumatic control

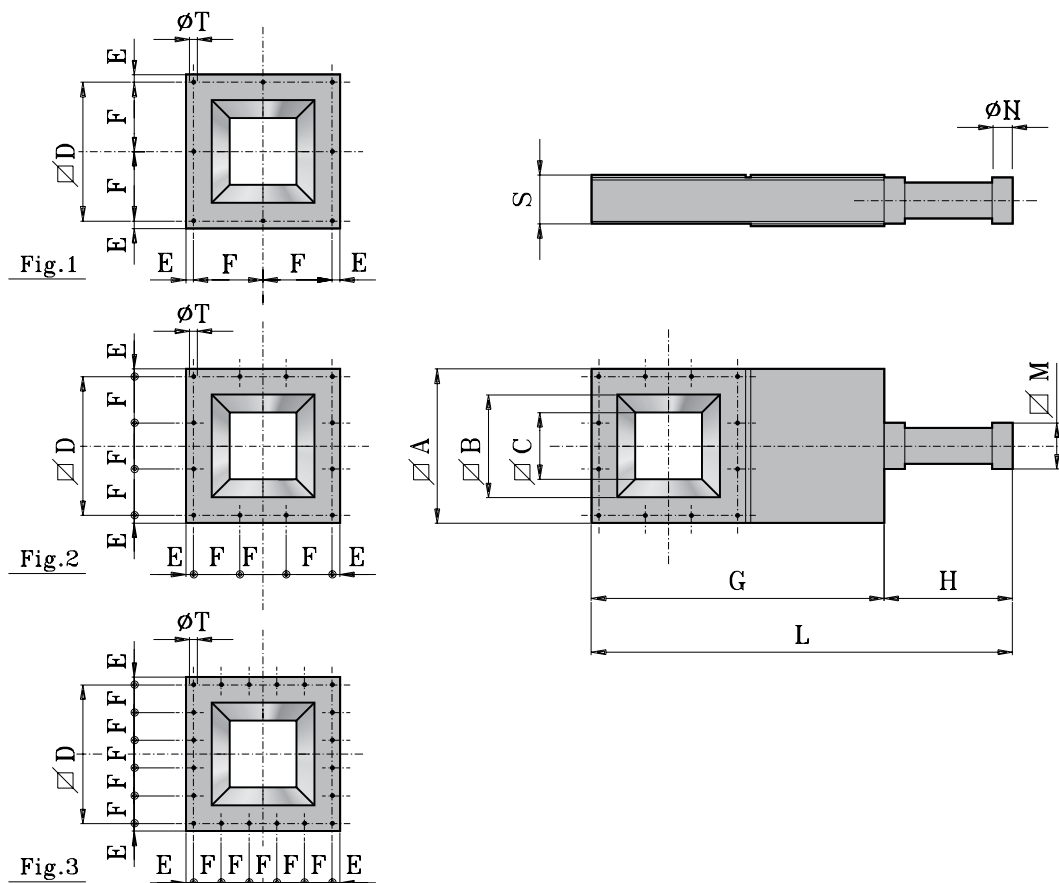

TYPE	Fig.	A	B	C	D	E	F	G	H	L	M	**	N	***	S	T	kg
.-SGBH150A.063	1	261	175	120	230	15,5	115	540	275	815	75	Ø 63X150	3/8"	2,8	93	12,5	18
.-SGBH200A.063	2	311	225	170	280	15,5	93,3	640	325	965	75	Ø 63X200	3/8"	3,7	93	12,5	21,5
.-SGBH250A.063	2	361	275	220	330	15,5	110	740	375	1115	75	Ø 63X250	3/8"	4,7	93	12,5	26,5
.-SGBH250A.080	2	361	275	220	330	15,5	110	740	412	1152	95	Ø 80X250	3/8"	7,5	93	12,5	28,5
.-SGBH300A.063	2	431	325	270	385	23	128,3	860	425	1285	75	Ø 63X300	3/8"	5,6	93	12,5	34,5
.-SGBH300A.080	2	431	325	270	385	23	128,3	860	462	1322	95	Ø 80X300	3/8"	9	93	12,5	38
.-SGBH350A.063	3	481	375	320	445	18	89	960	475	1435	75	Ø 63X350	3/8"	6,5	93	12,5	42
.-SGBH350A.080	3	481	375	320	445	18	89	960	512	1472	95	Ø 80X350	3/8"	10,3	93	12,5	44
.-SGBH400A.100	3	533	425	350	500	16,5	100	1090	545	1635	120	Ø 100X400	1/2"	18,8	133	12,5	70
.-SGBH400A.125	3	533	425	350	500	16,5	100	1090	595	1685	150	Ø 125X400	1/2"	29,4	133	12,5	76
.-SGBH500A.100	3	653	525	450	600	26,5	120	1300	645	1945	120	Ø 100X500	1/2"	23,6	133	15	90
.-SGBH500A.125	3	653	525	450	600	26,5	120	1300	695	1995	150	Ø 125X500	1/2"	36,8	133	15	97
.-SGBH600A.100	3	753	625	550	700	26,5	140	1500	745	2245	120	Ø 100X600	1/2"	28,3	133	15	122
.-SGBH600A.125	3	753	625	550	700	26,5	140	1500	795	2295	150	Ø 125X600	1/2"	44,2	133	15	128
.-SGBH700A.100	3	895	725	650	825	35	165	1720	845	2565	120	Ø 100X700	1/2"	33	133	15	158
.-SGBH700A.125	3	895	725	650	825	35	165	1720	895	2615	150	Ø 125X700	1/2"	51,5	133	15	169
.-SGBH800A.100	3	995	825	750	925	35	185	1920	945	2865	120	Ø 100X800	1/2"	37,7	133	15	204
.-SGBH800A.125	3	995	825	750	925	35	185	1920	995	2915	150	Ø 125X800	1/2"	58,9	133	15	216

\*\* Diameter and length of the pneumatic cylinder ISO 15552, up to size 350 delivered mounted - starting from size 400 delivered unmounted .

\*\*\* Air consumption (NI) at 6 bar for each operation.

# Accessories



## Identification

- /: Standard (without silencers)
- A: Atex (without silencers)
- II 2G Ex h IIB T5 Gb
- II 2D Ex h IIIC T100°C Db

Monostabile electro-valve  
5 ways - spring device

## Size

- 8 = 1/8"
- 4 = 1/4"

## Type

- C = Standard
- D = Atex

COMBINATION TABLE		
Ø CYLINDER	STANDARD	ATEX
Ø 63	KEC5182C	A-KEC5182D
Ø 80	KEC5182C	A-KEC5182D
Ø 100	KEC5142C	A-KEC5142D
Ø 125	KEC5142C	A-KEC5142D



## SILENCER



## STANDARD

- 1 = KEC5182C - 1/8"
- 3 = KEC5142C - 1/4"

## ATEX

- 8 = A-KEC5182D - 1/8"
- 4 = A-KEC5142D - 1/4"



## SOLENOID COIL



Solenoid coil and

## Voltage

- 024 = 24 V
- 048 = 48 V
- 115 = 115 V
- 230 = 230 V

## Frequency

- DC: Direct current DC
- AC: Alternating current AC 50/60 Hz

COMBINATION TABLE	
KEB 024 DC 3	KEB 024 AC 3
KEB 048 DC 3	KEB 048 AC 3
	KEB 115 AC 3
	KEB 230 AC 3

## SOLENOID COIL ATEX\*

CODE	POWER SUPPLY	PROTECTION LEVEL	CERTIFICATION
12A01358	24V DC	IP65	II 3G Ex nA IIC Tx Gc II 3D Ex tc IIIC Tx Dc
12A01352	24V AC		
12A01354	115V AC		



\* suitable for conductive and non-conductive powders





# Accessories

## LIMIT SWITCH IP67



### Dimension

**R1 (magnetic)** = SGB 150÷800 (20V÷220V AC / 20V÷220V DC)

**P (inductive)** = SGA 150 (20V÷220V AC) NO

**Q (inductive)** = SGA 200÷800 (20V-220V AC) NO

**S (inductive)** = SGA 150 (10V÷30V D.C.) PNP-NO

**T (inductive)** = SGA 200÷800 (10V÷30V DC) PNP-NO

### MAGNETIC

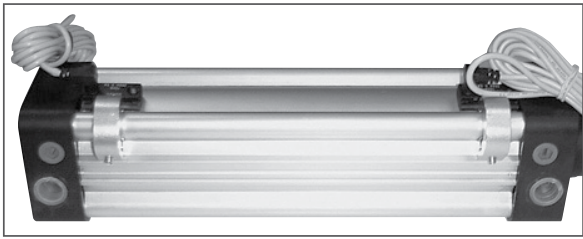

## LIMIT SWITCH ATEX IP67



### Dimension

**R (magnetic)** = A-SGB 150÷800 (10V÷110V AC / DC) II 3G Ex nC IICT4 Gc / II 3D Ex tc IIIC 110°C Dc

**S (inductive)** = A-SGA / A-SGB 150 (20V DC) PNP-NO II 3G Ex nAc IICT6 X / II 3D Ex tc IIIC T80°C X

**T (inductive)** = A-SGA / A-SGB 150 200÷800 (24V DC) PNP-NO II 3G Ex nAc IICT6 X / II 3D Ex tc IIIC T80°C X

### INDUCTIVE

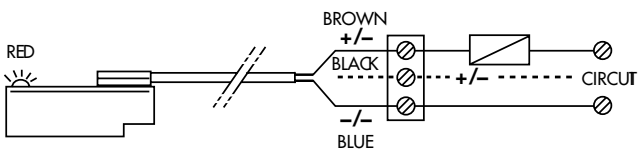
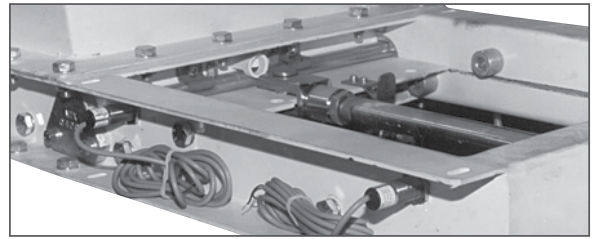

R1 - R

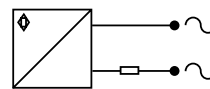

P - Q

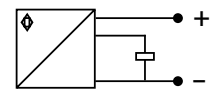

S - T

## SEAL SGA - SGB

The MIX packing box consists of two self-centering aluminium flanges which hold two shaped stainless steel profiles containing two square packings in a compressed adjustable position, which is also accessible when the valve is already installed. From size 250 onwards, the slide valve is equipped with screws, which allow to adjust the packing seal compression.

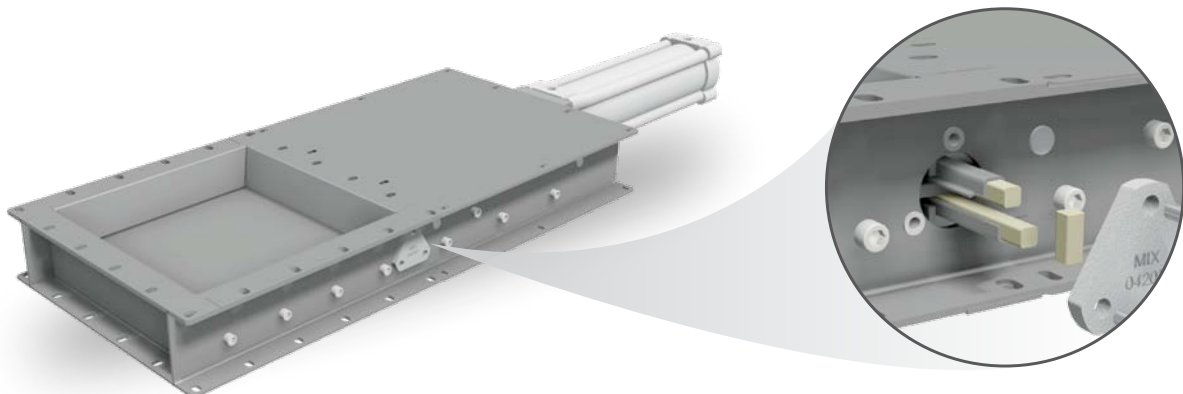

# Pinch Valve Combination table

**SMA**



**A**

**1**

**Nominal diameter**

080 = 80 mm  
100 = 100 mm

**Material for the seal**  
Anti-abrasive rubber

**Construction material**  
Body and flange in aluminium alloy

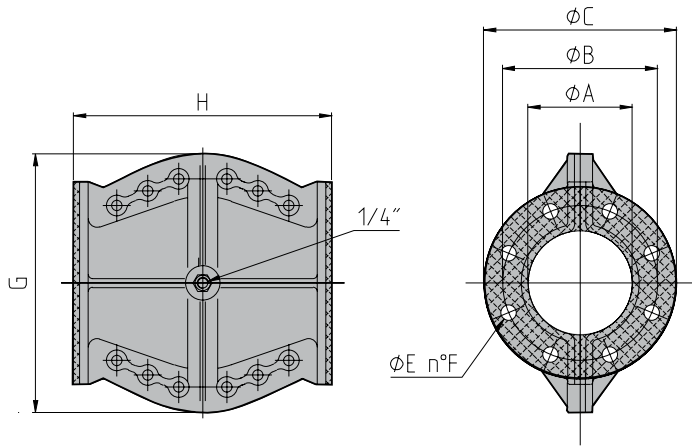

TYPE	A	B	C	E	F	G	H	kg
SMA 080	80	160	200	18	4	254	252	5,8
SMA 100	100	180	220	18	8	302	300	8,6

## DATA SHEET

**Working pressure:** max. 3 bar

**Control pressure:** 2 bar higher than the working pressure

**Temperature:** min. -10°C / max. +80°C

## ELECTRO-VALVE

**KEC**

**51**

**8**

**7**

**C**

Monostable electro-valve  
5 ways - spring device

**Dimension**  
8 = 1/8"

Standard



### INTERNAL ASSEMBLY CODE MIX

HSE10

KEC with SMA

## SILENCER

**70H3H24**

**1**

**TYPE**  
1 = KEC5181 - 1/8"

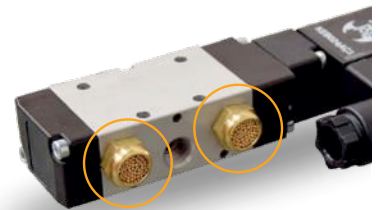

## SOLENOID COIL

**KEB**



**3**

**Solenoid coil and**

**Voltage**

024 = 24 V  
048 = 48 V  
115 = 115 V  
230 = 230 V

**Frequency**

DC: Direct current DC  
AC: Alternating current AC 50/60 Hz



### COMBINATION TABLE

KEB 024 DC 3	KEB 024 AC 3
KEB 048 DC 3	KEB 048 AC 3
	KEB 115 AC 3
	KEB 230 AC 3

# Accessories

## ROUND FLANGE FOR SMA

This flange is welded on the inlet feeding pipe of silo and the pinch valve is bolted to this flange.

**KFT**

Round flange

**Nominal diameter**  
080 = 80 mm  
100 = 100 mm

**D**  
D = UNI PN10

Construction material

**1** = Carbon steel  
**2** = Stainless steel AISI 304

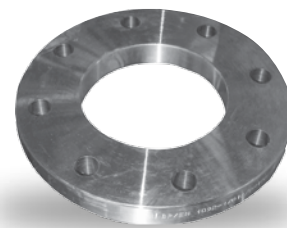

## PRESSURE SWITCH

It is used to control the air circuit of the pinch valve's control solenoid valve. It controls the compressed air pressure, making sure that it is higher than the minimum set point of 4 bar

**SSP**

Pressure switch

**2**

Type of contact  
NC/NO

**4**

Dimension  
Fittings 1/4"

**A**

Voltage  
24 - 230V AC

**1**

Equipment  
Standard with cable



### TECHNICAL DATA

Protection level	Working temperature	Voltage	Max applicable pressure	Pre-settled pressure	Current of NC Contact (resistive load / inductive load)	Current of NO Contact (resistive load / inductive load)
IP56	-20°C +70°C	Max 250V AC	10bar	4bar	15 A / 1,5 A	9 A / 0,9 A

## PRESSURE REDUCER

This unit, supplied together with a gauge and dehumidifying filter, makes it possible: to adapt system pressure to the correct operating pressure of either pinch valve whilst reducing the consumption of air; to increase the life of the pinch valve seal thanks to working with the correct pressure.

**SKR**

Pressure reducer

**4**

Fitting dimension  
4 = 1/4"

**E**

Working pressure  
0,5÷ 8,5 bar

**5**

Components  
Pressure reducer, gauge, dehumidifying filter

**B**

Fittings used  
With fittings for the SMA valve



### TECHNICAL DATA

Discharge of condensate	Weight	Fitting	Condensate separation	Working temperature	Vessel capacity
Semi-automatic	0,12 kg	G1/4"	> 90%	Max: +50°C	12 cm3

# Valves for Silos Combination table

**SV**

**C2**

**C**

**1**

**1**

**Connection flange**

**Q:** Squared connection made of carbon steel  
**T:** Round connection made of carbon steel  
 Fig.01

**Size**  
**250 - 300**

**Splined drive shaft**  
**DIN 5482**  
 Fig.02

**Material of body and pivoting**

**1:** Carbon steel painted  
 RAL 9006

**Standard powder seal in atmospheric pressure**

**Material of seal**  
**1:** NBR quality seal for continuous operation  
 (- 15°C+100°C)

Fig.01

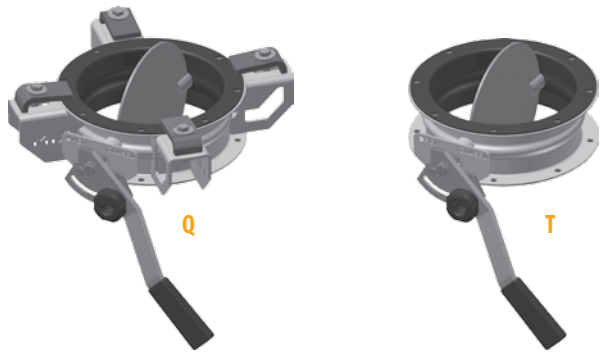
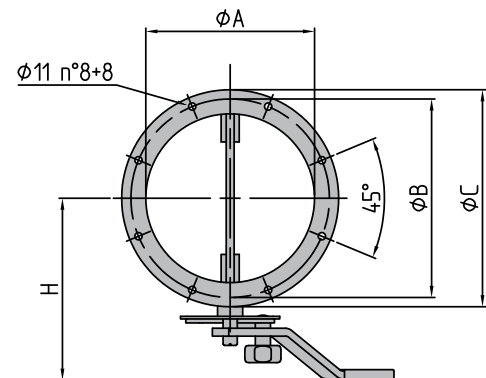
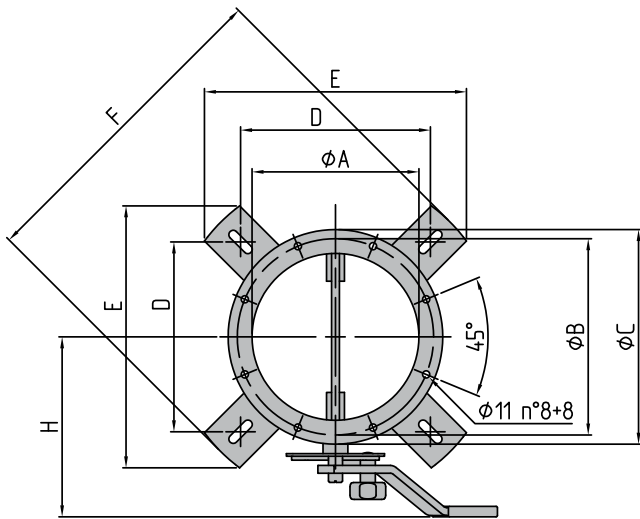
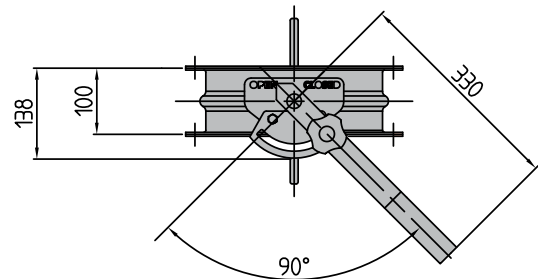
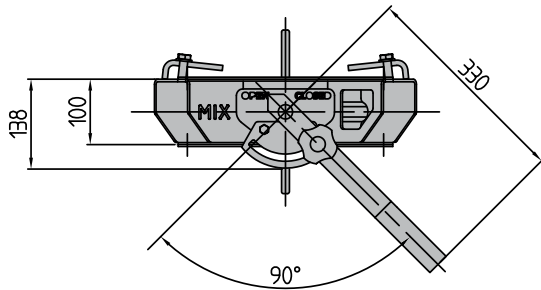

Fig.02



**SVQ**

**SVT**



TYPE	A	B	C	D	E	F	H	kg
SVQ250	250	300	328	290	400	500	275	14,2
SVQ300	300	350	378	350	490	620	300	16,7

TYPE	A	B	C	D	E	F	H	kg
SVT250	250	300	328	-	-	-	275	9,4
SVT300	300	350	378	-	-	-	300	11,2









# INTERCEPTION SYSTEMS AND COMPONENTS FOR PLANTS

QUALITY  
SERVICE  
TECHNOLOGY  
INNOVATION

[www.mixitaly.com](http://www.mixitaly.com)



**MIX S.r.l.** - 41032 CAVEZZO (MO) - Via Volturmo, 119/A - ITALY  
Tel. +39 0535.46577 - Fax +39 0535.46580 - [info@mixitaly.com](mailto:info@mixitaly.com)