

CONTROLLER

Introducing the intelligent robot controller based on Windows.
Robots and additional axis are easy to operate by using the teach pendant.
Vision and force sensors, as well as networks, are managed in one place.

CONTROLLER FD18



Basic specifications for controller

Item	Specifications
Controllable axes	6
Maximum controllable axes	8
External dimensions [mm]	300 (W) x 600 (D) x 1050 (H)
Max. I/O	2048
Maximum programmes	9999
Position reader	Absolute encoder
Protection rating	IP54
Power supply	three-phase 400 V, AC
Ambient temperature/humidity	0 to 40°C (50/60Hz) / 20 to 85% (without condensation)
Robot monitoring function	PL d (Cat. 3), optional: PL e

CONTROLLER CFD (FOR MZ-SERIES ONLY)



Basic specifications for controller

Item	Specifications
Controllable axes	6
Maximum controllable axes	7
External dimensions [mm]	369 (W) x 490 (D) x 250 (H)
Max. I/O	2048
Maximum programmes	9999
Protection rating	IP20
Power supply	one-phase 230 V, AC
Ambient temperature/humidity	0 bis 40°C/20 bis 85% (without condensation)
Robot monitoring function	PL d (Cat. 3), optional: PL e

CONTROLLER FD11



Basic specifications for controller

Item	Specifications
Controllable axes	6
Maximum controllable axes	8
External dimensions [mm]	580 (W) x 542 (D) x 1180 (H)
Max. I/O	2048
Maximum programmes	9999
Position reader	Absolute encoder
Protection rating	IP54
Power supply	three-phase 400 V, AC
Ambient temperature/humidity	0 to 40°C/20 to 85% (without condensation)
Robot monitoring function	PL d (Cat. 3), optional: PL e

CONTROLLER CFDL (FOR EZ-SERIES ONLY)



Basic specifications for controller

Item	Specifications		
	CFDL1-0000	CFDL2-0000	CFDL4-0000
Maximum controllable units	1	2	4
Maximum controllable axes	6 axes/unit		
External dimensions [mm]	369 (W) x 490 (D) x 250 (H)	369 (W) x 560 (D) x 327 (H)	
Protection rating	IP20		
Power supply	one-phase 230 V, AC		
Ambient temperature/humidity	0 to 40°C (50/60Hz) / 20 to 85% (without condensation)		



ROBOTS PORTFOLIO



CELEBRATE THE POLE POSITION



MADE IN JAPAN

NACHI-FUJIKOSHI CORP.

TOKYO

Shiodome Sumitomo Bldg., 1-9-2 Higashi-shinbashi, Minato-ku Tokyo, JAPAN
Phone: +81 3 5568-5240 | Fax: +81 3 5568-5236

TOYAMA

1-1-1 Fujikoshi-Honmachi, Toyama, JAPAN
Phone: +81 76 423-5111 | Fax: +81 76 493-5211

Web: www.nachi-fujikoshi.co.jp/

NACHI ROBOTICS SERVICE HOTLINE

Phone: +49 2151 8932-555 | Fax: +49 2151 8932-556 | Email: robot-service@nachi.de

NACHI EUROPE GmbH

Bischofstr. 99 | DE-47809 Krefeld, Germany | Phone: +49 2151 8932-500 | Fax: +49 2151 8932-501 | Web: www.nachi.de | Email: robotics@nachi.de

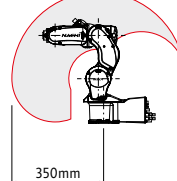
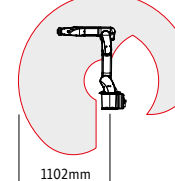
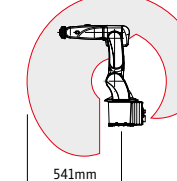
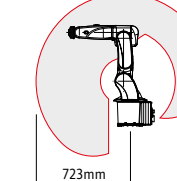
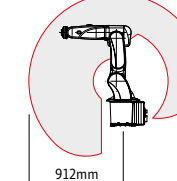
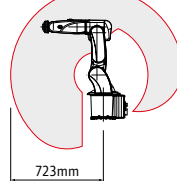
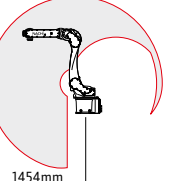
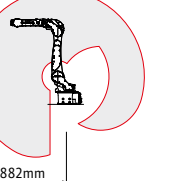
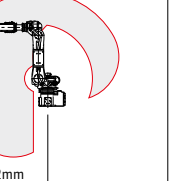
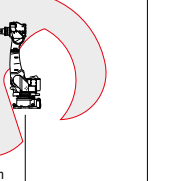
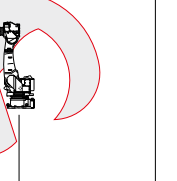
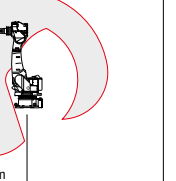
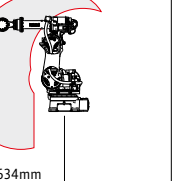
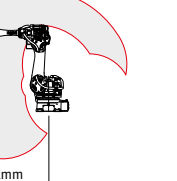
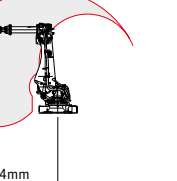

Robot Model:	MZ01	MZ03EL	MZ04 (MZ04D)	MZ07 (MZ07P)	MZ07L (MZ07LP)	MZ10	MZ12	MZ25	MC20	MC35	MC50	MC70	SRA100J-01	SRA100B-01	SRA100-01 (100-01A)
Max. Payload:	1kg	3,5kg	4kg	7	7kg	10kg	12kg	25kg	20kg	35kg	50kg	70kg	100kg	100kg	100kg
Max. Reach:	350mm	1102mm	541mm	723mm	912mm	723mm	1454mm	1882mm	1722mm	2050mm	2050mm	2050mm	1634mm	2071mm	2654mm
Repeatability:	±0.02mm	±0.03mm	±0.02mm	±0.02mm	±0.03mm	±0.02mm	±0.04mm	±0.05mm	±0.06mm	±0.07mm	±0.07mm	±0.07mm	±0.1mm	±0.1mm	±0.1mm
Protection Rating:	IP40	IP67	IP67	IP67	IP67	IP67	IP67	IP67	IP65	IP54/67	IP54/67	IP54/67	IP54/67	IP54/67	IP54/67
Vertical Coverage:															

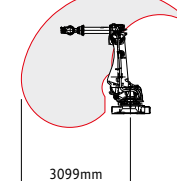
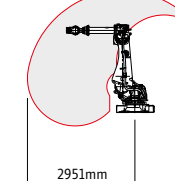
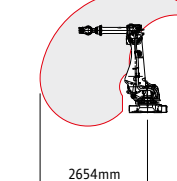
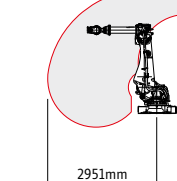
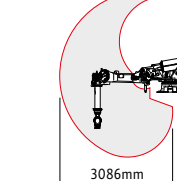
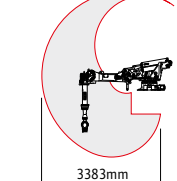
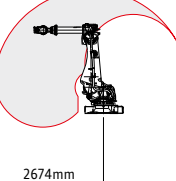
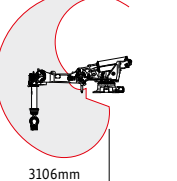
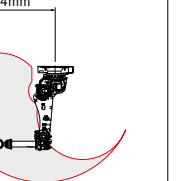
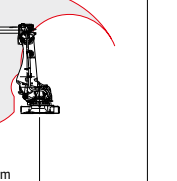
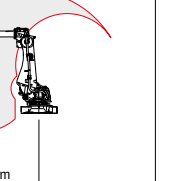
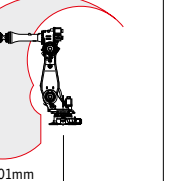
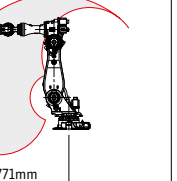
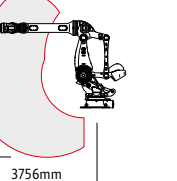
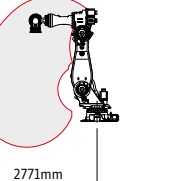
Robot Model:	SRA120EL-01	SRA133L-01	SRA166-01 (166-01A)	SRA166L-01 (166L-01A)	SRA166T-01 (166T-01A)	SRA166TL-01 (166TL-01A)	SRA210-01 (210-01A)	SRA210T-01 (210T-01A)	SRA210V	SRA240-01	SRA250-01	MC280L	MC350	MC400L	MC470P
Max. Payload:	120kg	133kg	166kg	166kg	166kg	166kg	210kg	210kg	210kg	240kg	250kg	280kg	350kg	400kg	470kg
Max. Reach:	3099mm	2951mm	2654mm	2951mm	3086mm	3383mm	2674mm	3106mm	2674mm	2674mm	2792mm	3101mm	2771mm	3756mm	2771mm
Repeatability:	±0.15mm	±0.15mm	±0.15mm	±0.15mm	±0.1mm	±0.15mm	±0.15mm	±0.15mm	±0.15mm	±0.2mm	±0.2mm	±0.2mm	±0.2mm	±0.3mm	±0.2mm
Protection Rating:	IP54/67	IP54/67	IP54/67	IP54/67	IP54/67	IP54/67	IP54/67	IP54/67	IP54/67	IP54/67	IP54/67	IP54	IP54	IP54	IP54
Vertical Coverage:															

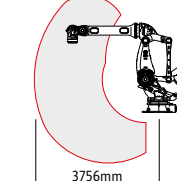
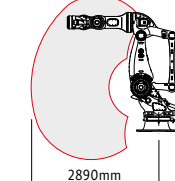
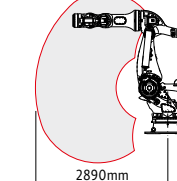
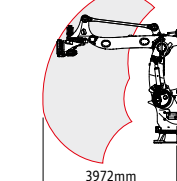
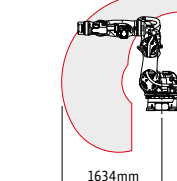
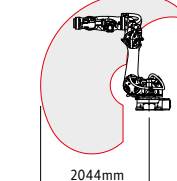
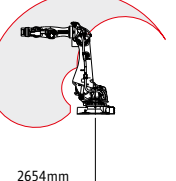
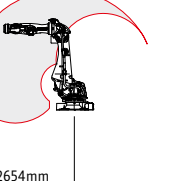
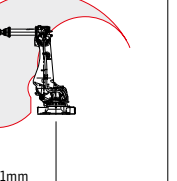
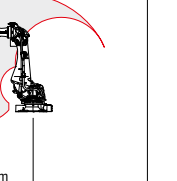
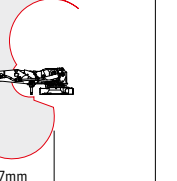
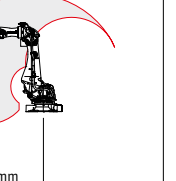
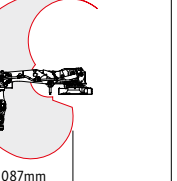
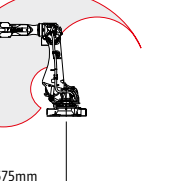
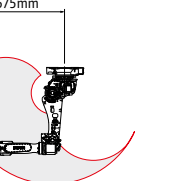
Robot Model:	MC500P	MC600	MC700	MC1000DL	SRA100HS	SRA100HB	SRA100H	SRA133H	SRA133HL	SRA166H	SRA166HT-01	SRA210H	SRA210HT-01	SRA220H	SRA220HV
Max. Payload:	500kg	600kg	700kg	1000kg	100kg	100kg	100kg	133kg	133kg	166kg	166kg	210kg	210kg	220kg	220kg
Max. Reach:	3756mm	2890mm	2890mm	3972mm	1634mm	2044mm	2654mm	2654mm	2951mm	2654mm	3087mm	2654mm	3087mm	2575mm	2575mm
Repeatability:	±0.3mm	±0.3mm	±0.3mm	±0.3mm	±0.1mm	±0.1mm	±0.1mm	±0.1mm	±0.15mm	±0.1mm	±0.1mm	±0.15mm	±0.15mm	±0.15mm	±0.15mm
Protection Rating:	IP54	IP54	IP54	-	IP54	IP54	IP54	IP54	IP54	IP54	IP54	IP54	IP54	IP54	IP54
Vertical Coverage:															

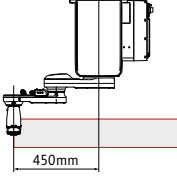
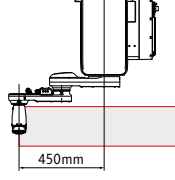
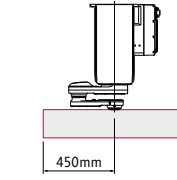
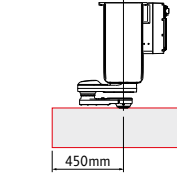
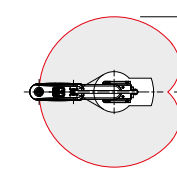
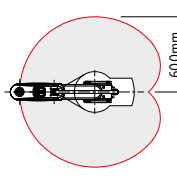
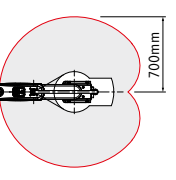
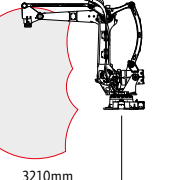
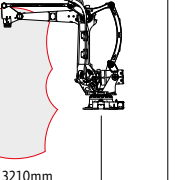
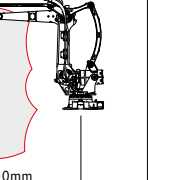
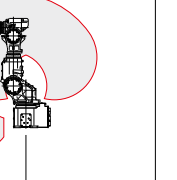
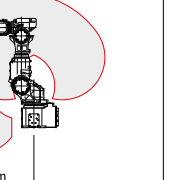
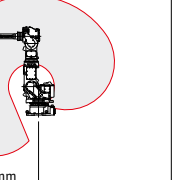
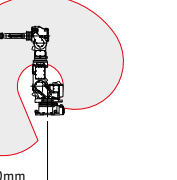
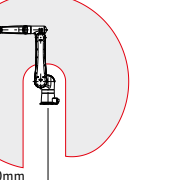
Robot Model:	EZ02-V6-02-4515	EZ02-V6-02-4525	EZ03-V4-4515	EZ03-V4-4525	EC06-5020-01	EC06-6020-01	EC06-7020-01	LP130F	LP180	LP210	MR20	MR20L	MR35	MR50	CZ10
Max. Payload:	2kg	2kg	3kg	3kg	6kg	6kg	6kg	130kg	180kg	210kg	20kg	20kg	35kg	50kg	10kg
Max. Reach:	450mm	450mm	450mm	450mm	500mm	600mm	700mm	3210mm	3210mm	3210mm	1260mm	1398mm	2050mm	2050mm	1300mm
Repeatability:	±0.02mm	±0.02mm	±0.014mm	±0.014mm	±0.02mm	±0.02mm	±0.02mm	±0.3mm	±0.4mm	±0.4mm	±0.06mm	±0.06mm	±0.07mm	±0.07mm	±0.1mm
Protection Rating:	IP20	IP20	IP20	IP20	IP20	IP20	IP20	IP54	IP54	IP54	IP65	IP65	IP67	IP67	IP54
Vertical Coverage:															

Please note: Robot specifications are subject to change without notice. Contact NACHI to check for the latest specifications.